

TRANSFLUID



drive with us



TRANSFLUID[®]

industrial & marine

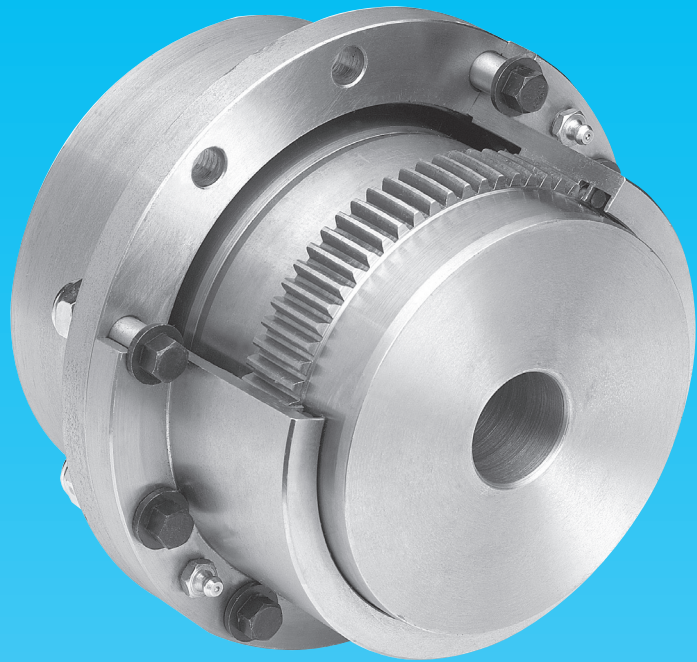

GEAR COUPLINGS P SERIES

CROWNED TOOTH GEAR COUPLINGS

P series

Maximum torque: up to 381.000 Nm (281,025 ft/lbs)
Bores: up to 370 mm

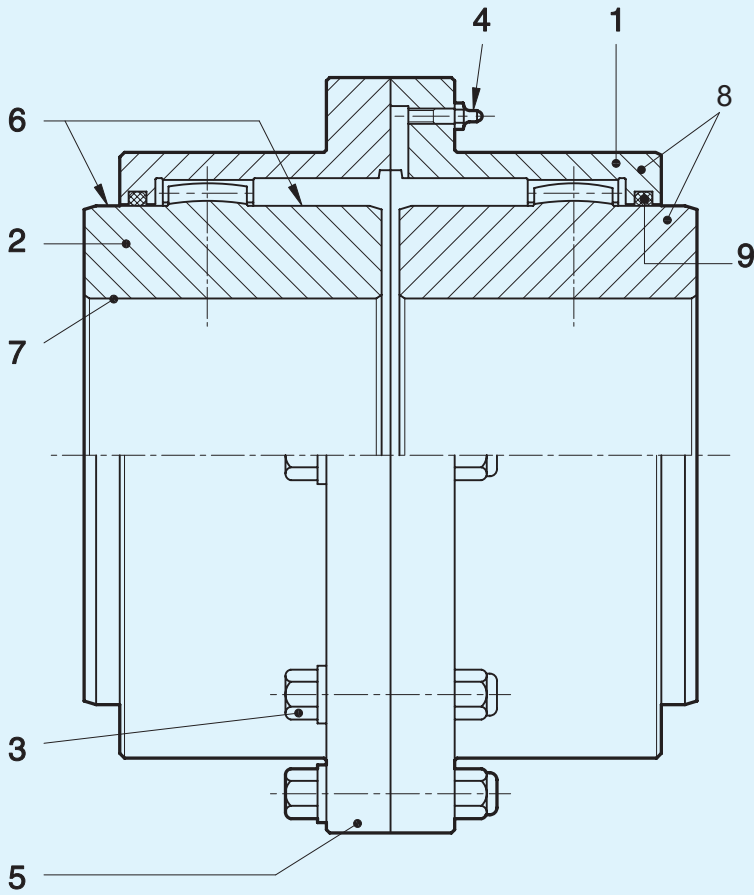

1. One piece sleeve with internal straight teeth
2. Hub teeth
3. Calibrated special-steel screws
4. Two lubrication plugs are mounted on each half sleeve
5. Flange supplied in exposed bolt version
6. Hub diameters are identical
7. Machined bore and keyway upon request
8. Steel forgings hubs and sleeves
9. O-Rings

• CROWNED HUB TEETH

Hub teeth are designed with a special crowned form to ensure a contact area larger than the conventional crowning. This solution involves reduced surface stresses and insuring a longer working life of the coupling.

HOW TO SELECT THE RIGHT COUPLING SIZE

- A.** The selection depends on the shaft outside diameter. It has to be less or equal to the max. bore inside diameter accepted.
B. Check the coupling capacity versus the actual job conditions, using the following formula

$$Nm = \frac{P \times F \times 9550}{n}$$

Where: P = Power in kW
 F = Service factor according to tabulation hereunder
 9550 = Fixed ratio
 n = Speed in Rev/min

- C.** Verify that the figured reading does not exceed the nominal torque.
 Max torque can be transmitted by the coupling during starts or for short periods of time.

TYPE OF LOAD	APPLICATIONS	SERVICE FACTOR	
		Electric motors Turbines	Hydraulic motors Gear drives
UNIFORM LIGHT SHOCKS	Blowers, generators, conveyors (belt and chain) Agitators (pure liquids), centrifugal pumps and compressors, escalators, machine tools: auxiliary drives. Textile machines, woodworking machinery. Can filling machines and bottling machinery.	1.5	1.75
MODERATE SHOCKS	Conveyors (belt and chain not uniformly fed, bucket, screw), gear pumps. Agitators (liquids variable density), multiple compressors, blowers (lobe), elevators, cranes, lift trucks, tackles and winches machine tools (main drives), winders (paper industry) wire winding machines, reels, propellers (ships).	1.75	2
HEAVY SHOCKS	Generators (welding), reciprocating compressors and pumps. Laundry washers, presses, hot rolling mills, bending rolls. Barkers, calenders, cement furnaces, draw bench, wire drawing and flattening machines.	2	2.25
VERY HEAVY SHOCKS	Crushers (ore and stone), hammer mills, rubber mills, road and railroad equipment, machines for agriculture.	2.5	2.75

LEGEND OF USED SYMBOLS		
	max.	Maximum bore (mm)
	min.	Minimum bore (mm)
	Tn	Nominal torque (Nm)
	Tp	Peak torque
	Max	Max speed (rpm)
		• Maximum offset (mm)
		• Maximum angular misalignment (degree) (on each side)
	J (WR ²)	Inertia (kgm)
		Weight (Kg)
		Grease quantity (Kg)

NOTES FOR DATA SHEETS
<ol style="list-style-type: none"> For key according to ISO R 773 (DIN 6885/1) Gear maximum continuous transmissible torque for the tabulated misalignment. The effective transmissible torque depends on the bore and shaft/hub connection. Higher speed on special request. <ol style="list-style-type: none"> For grease withstanding centrifugal acceleration of 1.000 g: see installation and maintenance manual For grease withstanding centrifugal acceleration of 2.000 g: see installation and maintenance manual Depends on L For solid bore <ol style="list-style-type: none"> Depends on L For pilot bored hubs <ol style="list-style-type: none"> Depends on L See installation and maintenance manual Values for S minimum. S maximum depends on torque and speed G must remain constant during operation Needed to control the alignment and inspect the gears

• Maximum values referred to a speed range from 0 to 250 rpm. For higher speed see installation and maintenance manual.

Type P

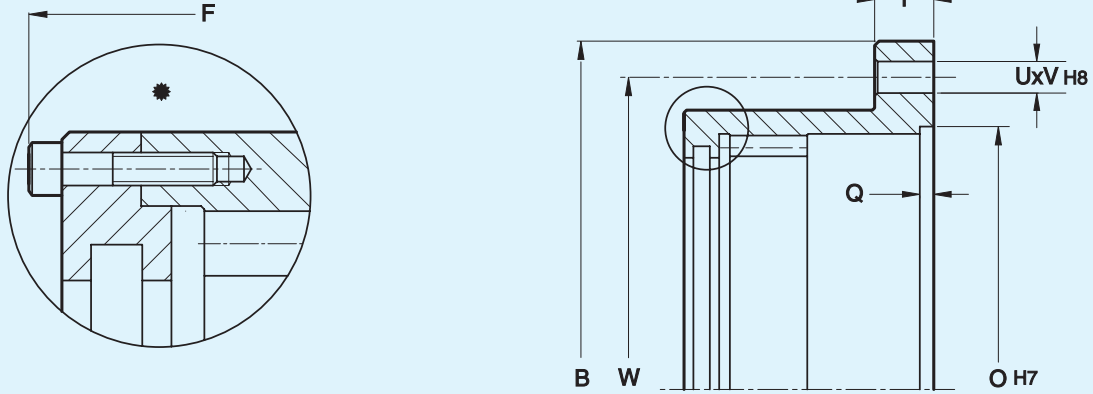

		2040	2055	2070	2085	2100	2120	2140	2160	2180	2200	2220	2250	2280	2320
P	mm	111	142	168	200	225	265	300	330	370	406	438	505	580	630
O	mm	80	100	122	148	172	200	232	260	286	315	345	400	432	480
Q	mm	3	3	3	3	3	4	4	5	5	5	5	6	5	5
T	mm	12	10	10	13	13	22	22	22	24	25	25	28	25	25
U	Qty.	6	8	10	10	12	12	14	14	14	14	14	16	18	22
V	mm	8	10	10	12	12	16	16	16	18	22	22	24	25	25
W	mm	96	122	148	178	203	236	270	300	335	368	400	460	530	580

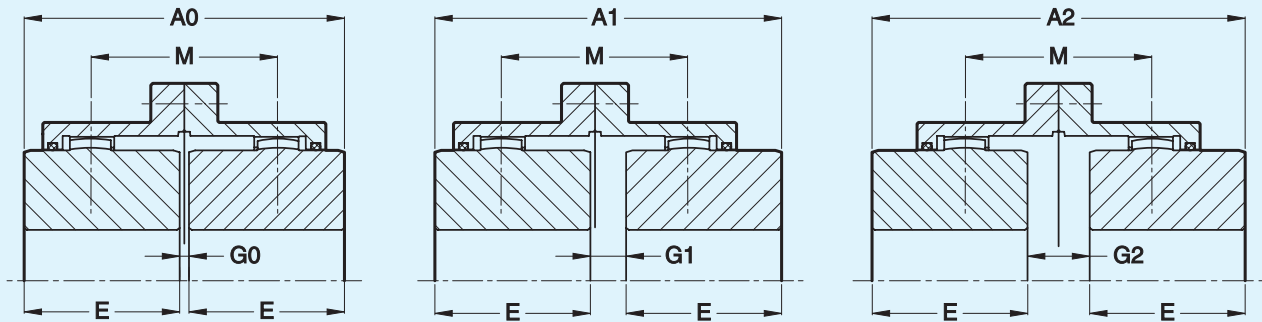

		2040	2055	2070	2085	2100	2120	2140	2160	2180	2200	2220	2250	2280	2320
A0	mm	89	103	127	157	185	216	246	278	308	358	388	450	512	562
A1	mm	91	108	138	164	204	237	272	307	350	403	438	512	564	629
A2	mm	93	113	149	171	223	258	298	336	392	448	488	574	616	696
E	mm	43	50	62	76	90	105	120	135	150	175	190	220	250	275
G0	mm	3	3	3	5	5	6	6	8	8	8	8	10	12	12
G1	mm	5	8	14	12	24	27	32	37	50	53	58	72	64	79
G2	mm	7	13	25	19	43	48	58	66	92	98	108	134	116	146
M	mm	48	58	76	88	114	132	152	172	200	228	248	292	-	-

Type PST

see page 2

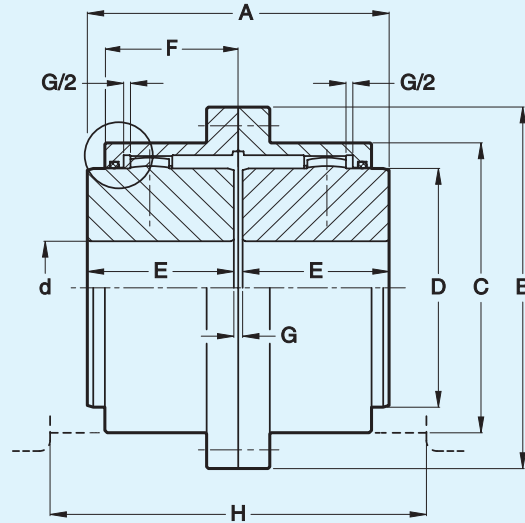
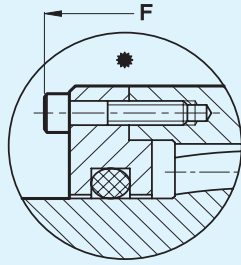

			Type PST														
			2040	2055	2070	2085	2100	2120	2140	2160	2180	2200	2220	2250	2280	2320	
	max	1	mm	50	60	75	95	110	130	155	170	190	210	230	280	325	370
	min		mm	12	18	28	40	50	60	70	85	95	110	120	130	150	170
	Tn	2	Nm*	1700	2700	5500	8500	13500	22000	34000	43000	68000	82000	150000	195000	275000	381000
	Tp			4100	6200	12000	21000	34000	54000	83000	99000	156000	195000	348000	479000	550000	762000
	max	3.1	rpm	5000	4400	4000	3600	3350	3100	2800	2700	2550	2320	2100	1800	1200	980
		3.2															
		-	degree	2 x 0.150													
		-	mm±	0.25				0.50				0.80			0.90		
		4	kgm ²	0.005	0.012	0.032	0.084	0.162	0.375	0.728	1.225	3.105	3.401	5.052	10.32	20.60	33.50
		5	kg	4	8	13	26	37	59	91	123	170	234	295	455	685	920
		6	kg	0.08	0.09	0.15	0.25	0.45	0.70	0.90	1.54	2.3	3.2	3.9	5.4	6.5	7.2
Dimensions	A		mm	89	103	127	157	185	216	246	278	308	358	388	450	512	562
	B		mm	111	142	168	200	225	265	300	330	370	406	438	505	580	630
	C		mm	82.5	104.5	130.5	158.5	183.5	211.5	245.5	275	307	335	367	423	495	545
	D		mm	69	85	107	133	152	178	209	234	254	279	305	355	400	450
	E		mm	43	50	62	76	90	105	120	135	150	175	190	220	250	275
	F		mm	39	45.5	59	68.5	82.5	93	106	118	138	154	166	193	223	247
	G		mm	3	3	3	5	5	6	6	8	8	8	8	10	12	12
	H	10	mm	119	139	177	195	245	266	276	318	398	448	480	556	-	-

*ft/lbs	1253	1991	4056	6267	9957	16227	25078	31716	50156	61220	115065	143832	202840	281025
	3024	6200	8851	15489	25078	39830	61220	73022	115065	143832	256684	353310	405680	562051

Type PMM

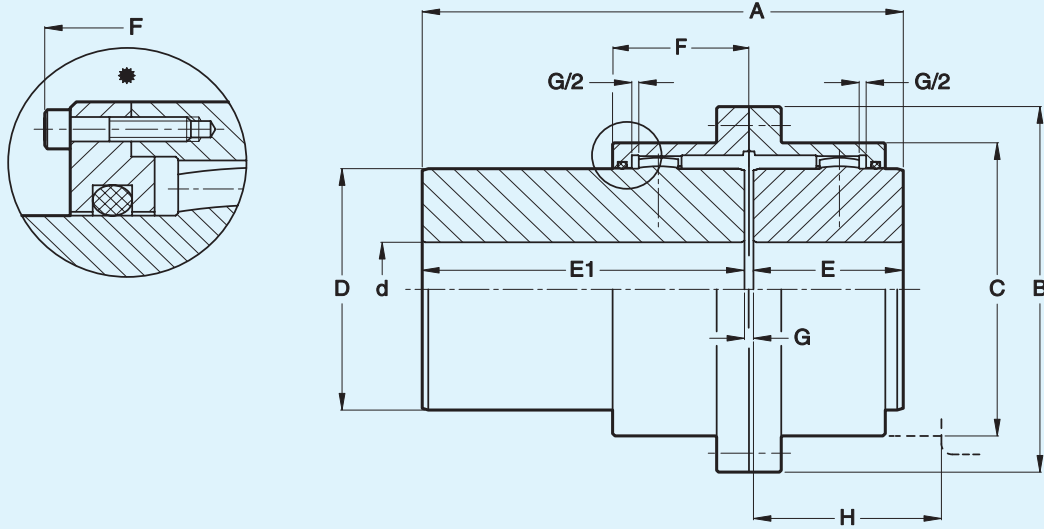

see page 2

			Type PMM																
			2040	2055	2070	2085	2100	2120	2140	2160	2180	2200	2220	2250	2280	2320			
	d	max	1	mm	50	60	75	95	110	130	155	170	190	210	230	280	325	370	
		min		mm	12	18	28	40	50	60	70	85	95	110	120	130	150	170	
	Tn		2	Nm	1700	2700	5500	8500	13500	22000	34000	43000	68000	82000	150000	195000	275000	381000	
	Tp				4100	6200	12000	21000	34000	54000	83000	99000	156000	195000	348000	479000	550000	62000	
	max		3.1	rpm	500	4400	4000	3600	3350	3100	2800	2700	2550	2320	2100	1800	1200	980	
			3.2																
	α		-	degree	2 X 0.150														
			-	mm±	0.25				0.50				0.80			0.90			
	J (WR ²)		4	kgm ²	0.006	0.015	0.039	0.101	0.196	0.440	0.869	1.48	2.57	3.975	5.601	11.41	-	-	
			5	kg	6	10.40	17	32	46	72	113	152	215	276	339	501	-	-	
	Grasse		6	kg	0.08	0.09	0.15	0.25	0.45	0.70	0.90	1.54	2.3	3.2	3.9	5.4	7.5	9.5	
Dimensions	A			mm	151	168	195	231	265	296	341	388	453	483	503	540	-		
	B			mm	111	142	168	200	225	265	300	330	370	406	438	505	580	630	
	C			mm	82.5	104.5	130.5	158.5	183.5	211.5	245.5	275	307	335	367	423	495	545	
	D			mm	69	85	107	133	152	178	209	234	254	279	305	355	400	450	
	E			mm	43	50	62	76	90	105	120	135	150	175	190	220	250	275	
	E1			mm	105	115	130	150	170	185	215	245	295	300	305	310	AS REQUIRED		
	F			mm	39	45.5	59	68.5	82.5	93	106	118	138	154	166	193	223	247	
	G			mm	3	3	3	5	5	6	6	8	8	8	8	10	12	12	
	H	10			mm	58	68	87	95	120	130	135	155	195	220	236	273	-	-

*ft/lbs	1253	1991	4056	6267	9957	16227	25078	31716	50156	60483	115065	143832	202840	281025
	3024	6200	8851	15489	25078	39830	61220	73022	115065	143832	256684	353310	405680	45731

Type PDMM

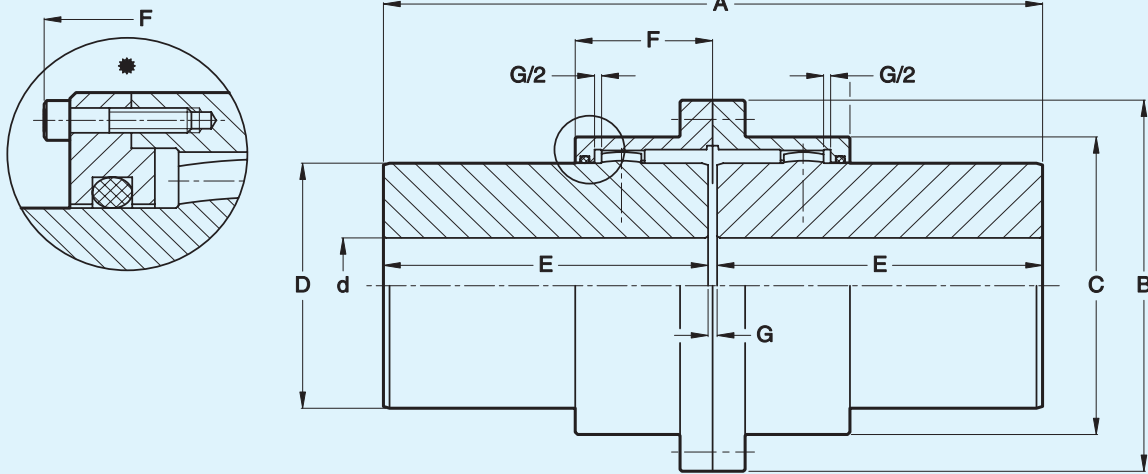

see page 2

			Type PDMM														
			2040	2055	2070	2085	2100	2120	2140	2160	2180	2200	2220	2250	2280	2320	
	max	1	mm	50	60	75	95	110	130	155	170	190	210	230	280	325	370
	min		mm	12	18	28	40	50	60	70	85	95	110	120	130	150	170
	Tn	2	Nm*	1700	2700	5500	8500	13500	22000	34000	43000	68000	82000	150000	195000	275000	381000
	Tp			4100	6200	12000	21000	34000	3100	83000	99000	156000	195000	348000	479000	550000	762000
	max	3.1 3.2	rpm	5000	4400	4000	3600	3350	3100	2800	2700	2550	2320	2100	1800	1200	980
	-	-	degree	2 x 0.150													
	-	-	mm±	0.25				0.50				0.80			0.90		
	J (WR ²)	4	kgm ²	0.007	0.018	0.045	0.118	0.230	0.505	1.010	1.735	3.03	4.55	6.15	12.5	-	-
		5	kg	7.9	12.7	21	38	55	84	134	180	260	317	3.82	546	-	-
		6	kg	0.08	0.09	0.15	0.25	0.45	0.70	0.90	1.54	2.3	3.2	3.9	5.4	7.5	9.5
Dimensions	A		mm	213	233	263	305	345	376	436	498	598	608	618	630	-	-
	B		mm	111	142	168	200	225	265	300	330	370	406	438	505	580	630
	C		mm	82.5	104.5	130.5	158.5	183.5	211.5	245.5	275	307	335	367	423	495	545
	D		mm	69	85	107	133	152	178	209	234	254	279	305	355	400	450
	E		mm	105	115	130	150	170	185	215	245	295	300	305	310	AS REQUIRED	
	F		mm	39	45.5	59	68.5	82.5	93	106	118	138	154	166	193	223	247
	G		mm	3	3	3	5	5	6	6	8	8	8	8	10	12	12

*ft/lbs	1253	1991	4056	6267	9957	16227	25078	31716	50156	61220	115065	143832	202840	281025
	3024	6200	8851	15489	25078	2286	61220	73022	115065	143832	256684	353310	405680	562051

Type PFS

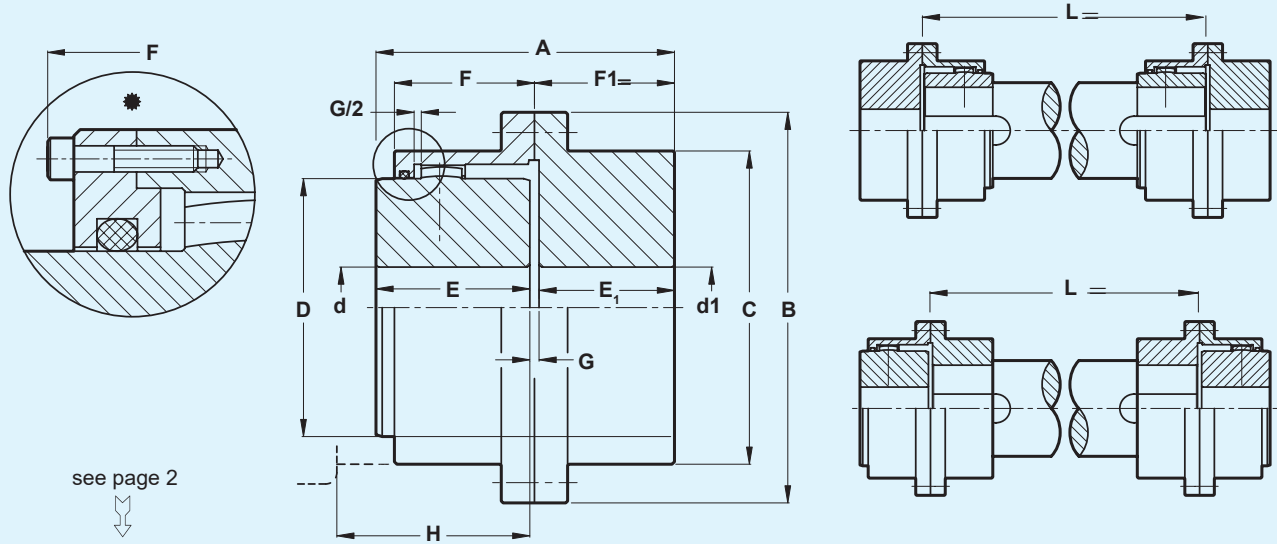

				Type PFS													
				2040	2055	2070	2085	2100	2120	2140	2160	2180	2200	2220	2250	2280	2320
	max	1	mm	50	60	75	95	110	130	155	170	190	210	230	280	325	370
			mm	12	18	28	40	50	60	70	85	95	110	120	130	150	170
	max		mm	60	75	90	110	130	150	175	195	220	240	260	300	365	395
	Tn Tp	2	Nm	1700	2700	5500	8500	13500	22000	34000	43000	68000	82000	150000	195000	275000	381000
				4100	3200	12000	21000	34000	54000	83000	99000	156000	195000	348000	479000	550000	762000
	max	3.3	rpm														
	-		degree	0.150													
	J (WR ²)	4	kgm ²	0.005	0.014	0.035	0.090	0.180	0.410	0.780	1.33	2.28	3.73	5.59	10.55	21.11	34.5
		5	kg	4.6	8.5	13.8	27	39.5	62.5	94.6	130	181	250	320	490	718	940
	Grasse	6	kg	0.04	0.05	0.08	0.14	0.24	0.34	0.47	0.77	1.14	1.55	1.95	2.85	3.80	4.85
Dimensions	A		mm	89	103	127	157	185	216	246	278	308	358	388	450	512	562
	B		mm	111	142	168	200	225	265	300	330	370	406	438	505	580	630
	C		mm	82.5	104.5	130.5	158.5	183.5	211.5	245.5	275	307	335	367	423	475	520
	D		mm	69	85	107	133	152	178	209	234	254	279	305	355	400	450
	E		mm	43	50	62	76	90	105	120	135	150	175	190	220	250	275
	E1		mm	39	45.5	59	68.5	82.5	93	106	118	138	154	166	193	223	247
	F		mm	44.5	51.5	63.5	78.5	92.5	108	123	139	154	179	194	225	256	281
	G		mm	3	3	3	5	5	6	6	8	8	8	8	10	12	12
H	10	mm	58	68	87	95	120	130	135	155	195	220	236	273	-	-	

*ft\lbs	1253	1991	4056	6267	9957	16227	25078	31716	50156	60483	115065	143832	202840	281025
	3024	2360	8851	15489	25078	39830	61220	73022	115065	143832	256684	353310	405680	562051

Type PSV

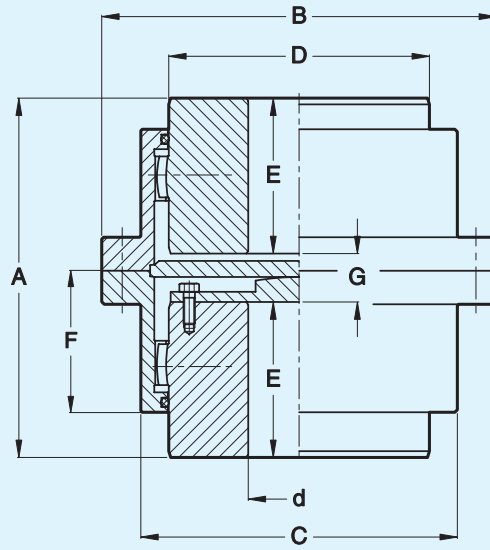

see page 2





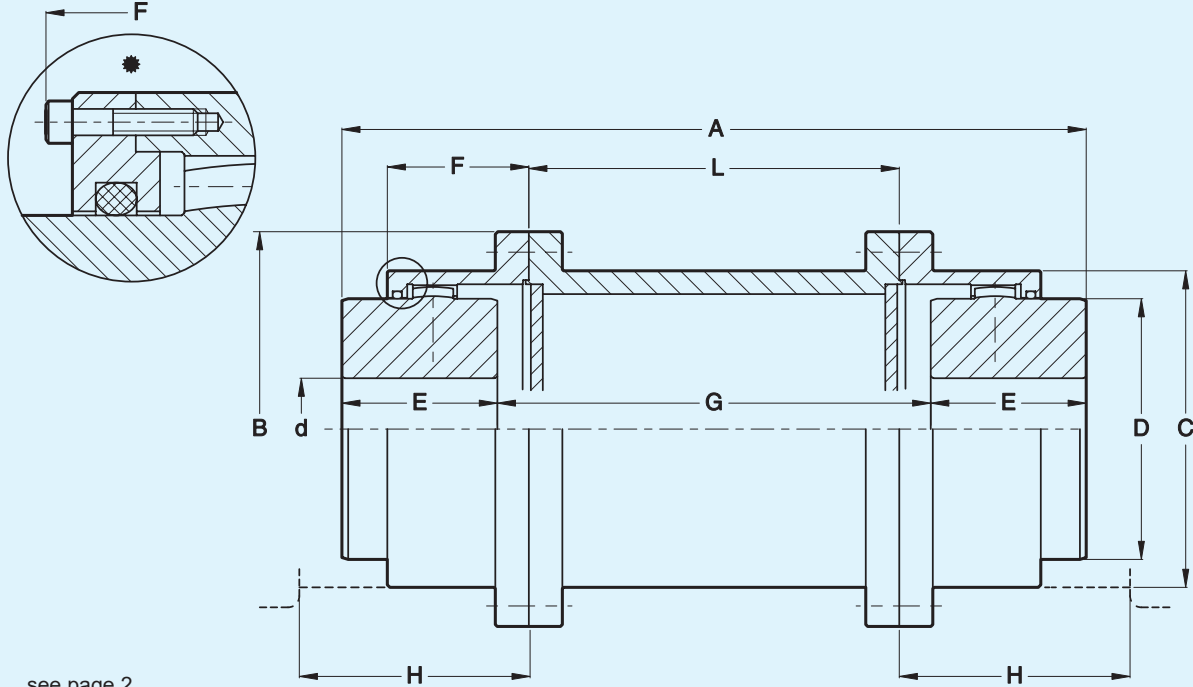

			Type PSV											
			2040	2055	2070	2085	2100	2120	2140	2160	2180	2200	2220	2250
	d	max	50	60	75	95	110	130	155	170	190	210	230	280
		min	12	18	28	40	50	60	70	85	95	110	120	130
	Tn		1700	2700	5500	8500	13500	22000	34000	43000	68000	8200	150000	195000
	Tp		4100	6200	12000	21000	34000	54000	83000	99000	156000	195000	348000	479000
	max	rpm	5000	4400	4000	3600	3350	3100	2800	2700	2550	2320	2100	1800
	-	degree	2 x 0.150											
	-	mm±	0.25				0.50				0.80			
	J (WR ²)	kgm ²	0.005	0.012	0.032	0.084	0.162	0.375	0.728	1.225	2.105	3.401	5.052	10.32
		kg	5	9	15	28	49	62	95	129	178	244	307	470
		kg	2x0.04	2x0.045	2x0.051	2x0.13	2x0.23	2x0.35	2x0.45	2x0.77	2x1.15	2x1.6	2x1.95	2x3.12
Dimensions	A	mm	109	123	155	183	223	258	298	336	392	448	488	574
	B	mm	111	142	168	200	225	265	300	330	370	406	438	505
	C	mm	82.5	104.5	130.5	158.5	183.5	211.5	245.5	275	307	335	367	423
	D	mm	69	85	107	133	152	178	209	234	254	279	305	355
	E	mm	43	50	62	76	90	105	120	135	150	175	190	220
	F	mm	39	45.5	59	68.5	82.5	93	106	118	138	154	166	193
	G	mm	23	23	31	31	43	48	58	66	92	98	108	134

*ft\lbs	1253	1991	4056	6267	9957	16227	25078	31716	50156	6048	110640	143832
	3024	2360	8851	15489	25078	39830	61220	73022	115065	143832	256684	353310

Type PSE



see page 2

			Type PSE														
			2040	2055	2070	2085	2100	2120	2140	2160	2180	2200	2220	2250	2280	2320	
 d	max	1	mm	50	60	75	95	110	130	155	170	190	210	230	280	325	370
	min		mm	12	18	28	40	50	60	70	85	95	110	120	130	150	170
 T _n T _p		2	Nm	1700	2700	5500	8500	13500	22000	34000	43000	68000	82000	150000	195000	275000	381000
				4100	6200	12000	21000	34000	54000	83000	99000	156000	195000	348000	479000	550000	762000
	max	3.3	rpm														
		-	degree	0.150													
 J (WR ²)	4.1		kgm ²														
	5.1		kg														
	6		kg	2x0.04	2x0.05	2x0.07	2x0.14	2x0.24	2x0.30	2x0.50	2x0.80	2x1.20	2x1.60	2x2.00	2x3.10	2x3.8	2x4.85
Dimensions	A	8	mm	173	203	239	271	323	368	408	466	542	608	658	754	upon request	
	B		mm	111	142	168	200	225	265	300	330	370	406	438	505	580	630
	C		mm	82.5	104.5	130.5	158.5	183.5	211.5	245.5	275	307	335	367	423	495	545
	D		mm	69	85	107	133	152	178	209	234	254	279	305	355	400	450
	E		mm	43	50	62	76	90	105	120	135	150	175	190	220	250	275
	F		mm	39	45.5	59	68.5	82.5	93	106	118	138	154	166	193	223	247
	G	8	mm	87	103	115	119	143	158	168	196	242	258	278	314	upon request	
	H	10	mm	59.5	69.5	88.5	97.5	122.5	133	138	159	199	224	240	278	-	-
Lmin	8	mm	80	90	90	100	100	110	110	130	150	160	170	180	upon request		
*ft/lbs	1253	1991	4056	6267	9957	16227	25078	31716	50156	60483	110640	143832	202840	281025			
	3024	4573	8851	15489	25078	39830	61220	73022	115065	143832	256684	353310	405680	562051			

Standard available types

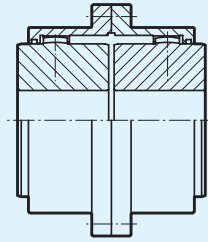

PST standard

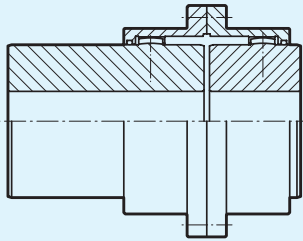

PMM mill motor

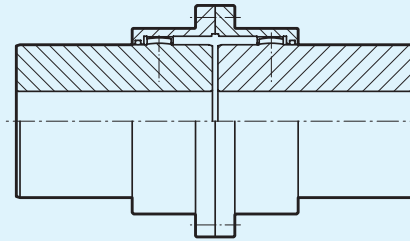

PDMM double mill motor

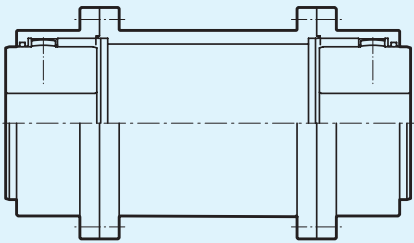

PSE spacer execution

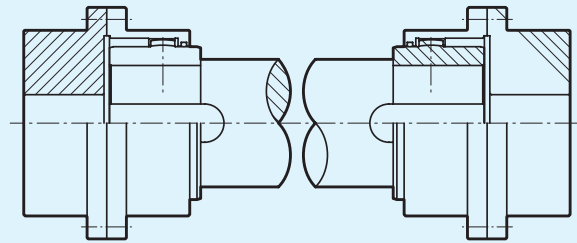

PFS floating shaft

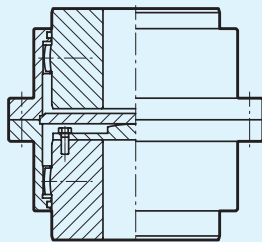

PSV standard vertical

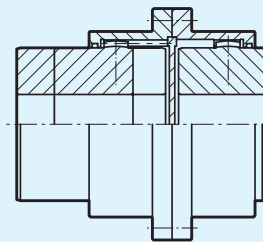

PSH sliding hub

PBD with brake disc

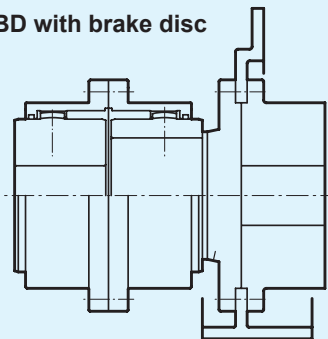

PBP with brake pulley

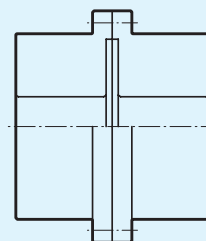

PRR rigid-rigid

OTHER TRANSFLUID PRODUCTS

FLUID COUPLING K SERIES

Oil or water constant fill
Up to (3352 hp) 2500 kW



FLUID COUPLING KX SERIES

Oil or water constant fill
low drag torque
Up to (1341 hp) 1000 kW

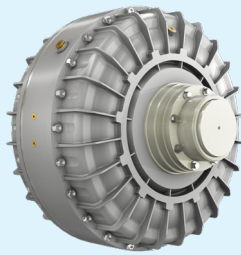

FLUID COUPLING KSL SERIES

Start up and variable
speed drive
Up to (5364 hp) 4000 kW

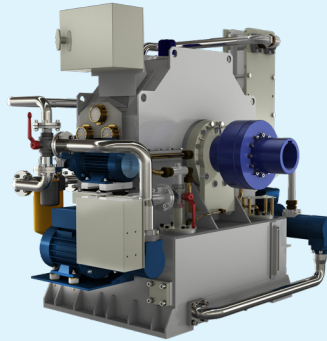

FLUID COUPLING KPT SERIES

Start up and variable
speed drive
Up to (2279 hp) 1700 kW

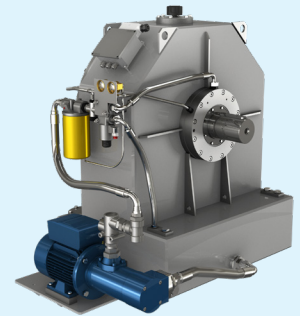

FLEXIBLE COUPLING BM-B3M SERIES

Up to (24414 ft/lbs) 33100 Nm

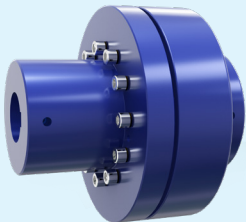

AIR AND HYDRAULIC CLUTCH HYDRAULIC BRAKE TP-SHC-SL SERIES

Up to (8482 ft/lbs) 11500 Nm
Up to (1844 ft/lbs) 2500 Nm
Up to (6638 ft/lbs) 9000 Nm

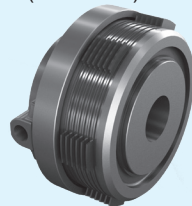

DISC AND DRUM BRAKE NBG-TFDSSERIES

Up to (14014 ft/lbs) 19000 Nm

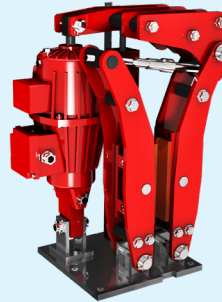

OIL OPERATED POWER TAKE OFF HF SERIES

Up to (1743 hp) 1300 kW

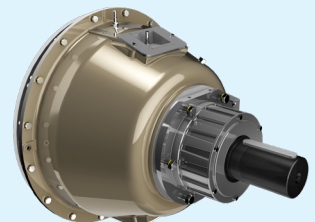

FLUID COUPLING KPTO SERIES

For internal combustion engine
P.T.O. for pulley and cardan shaft
Up to (1341 hp) 1000 kW

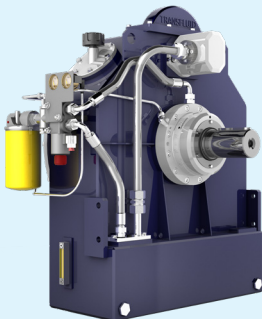

MULTI PUMP DRIVE STELLADRIVE SERIES

Up to (1743 hp) 1300 kW

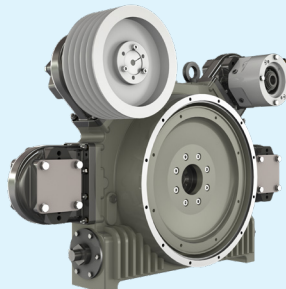

POWER SHIFT TRANSMISSION

With torque converter
Up to three speeds
Electric selector
Up to (127 hp) 95 kW

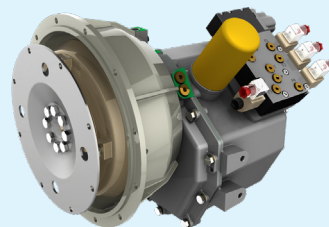

ELASTIC COUPLING RBD SERIES

For internal combustion engine
Up to (11801 ft/lbs) 16000 Nm



U.S.A
TRANSFLUID LLC
Auburn, GA 30011
Ph.: +1.770.822.1777
salesna@transfluid.us

NORTH EUROPE
TRANSFLUID B.V.
(Bellmarine)
NL-3992 AK, Houten
Ph. +31 (0)85 4868530
info@bellmarine.nl