



# TRANSFLUID<sup>®</sup>

**industrial & marine**

# TRANSFLUID



**drive with us**

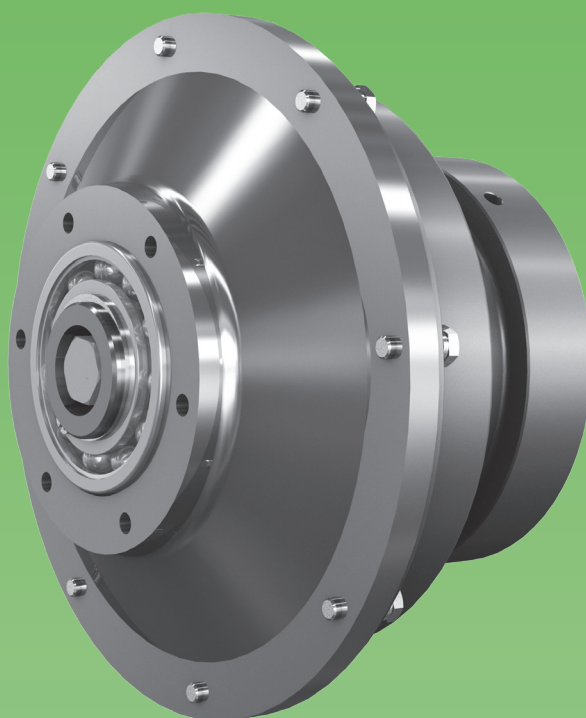

**TPO - TPH**

AIR ACTUATED CLUTCHES

# TPO AIR CLUTCHES

## MAIN FEATURES

TRANSFLUID air clutches are durable and reliable components. Their technical development has been achieved with years of experience in the field of transmissions.

With transmittable torques of up to 14000 Nm (10236 ft/lbs) and being self-adjusting, they satisfy many different applications. Air actuation allows for easy engagement control and they can be remote controlled.

The main technical features are:

- Operating discs made of a high quality cast iron with large surfaces to dissipate heat generated from friction
- The friction discs are made of an asbestos-free composite compound that is molded with external gear teeth to interface with the internal teeth of the drive ring
- TPO clutches have compact external dimensions allowing easy installation
- The hubs have enlarged bore capacities to allow shafts with large diameters to be used
- The compact design allows two or three plate clutches to be used in the envelope where a single disc clutch typically would mount

## Medium series

The TPO clutches sizes 8" and 10" are manufactured with a vulcanized tube made with a nylon reinforced neoprene compound to eliminate leakage and provide a very long operational life. The medium series is interchangeable in components and dimensions with the corresponding Twin Disc production.

## Heavy series

The core of 14" and 18" TPO clutch is an elastomeric diaphragm developed after in-depth research and development. This development resulted in a longest life diaphragm on the market. Because of the large air volume used to engage the heavy series of clutches they are supplied with an integrated quick release valve to provide rapid disconnect. The smaller clutches are typically not fitted with the quick release valve as long as the actuator is positioned near the TPO.

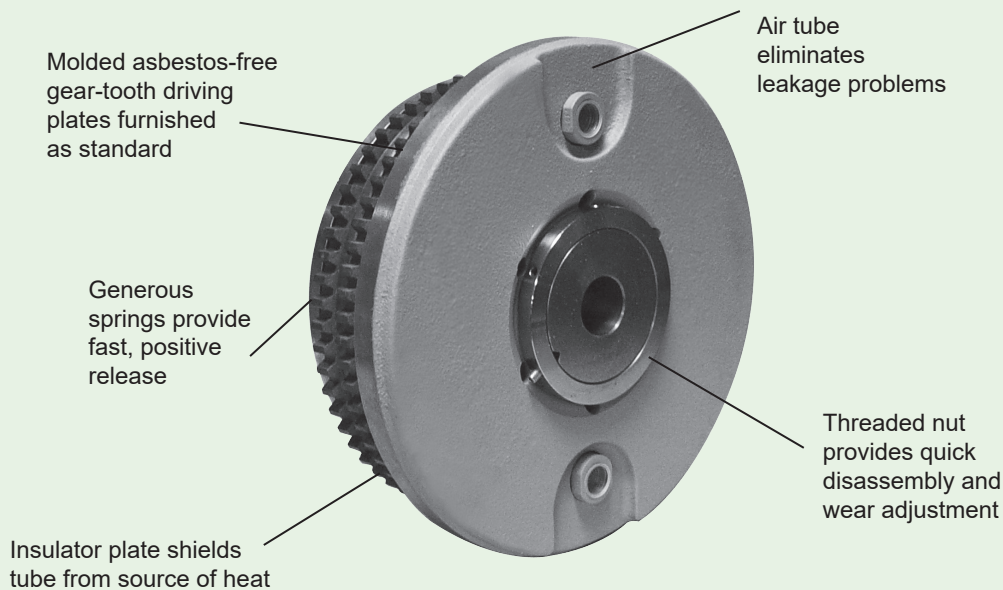

Tab.1 - PERFORMANCES

MODEL	Input Torque Tkn				Max oper. speed	Air volume to engage (fully worn disc)	
	7 bar (100 Psi)		9 bar (130 Psi)			rpm	cm <sup>3</sup>
	Nm	ft/lbs	Nm	ft/lbs			
TPO-208	860	635	1100	825	4000	180	11
TPO-308	1300	960	1680	1450	4000	213	13
TPO-210	1800	1330	2700	1740	3600	262	16
TPO-310	2670	1973	3450	2620	3600	311	19
TPO-214	5840	4315	7650	5625	2500	1080	66
TPO-314	8760	6473	11440	8437	2500	1160	71
TPO-318	13670	10100	16800	12400	2050	1220	74

## TPO AIR CLUTCHES

TPO 208 - TPO 310

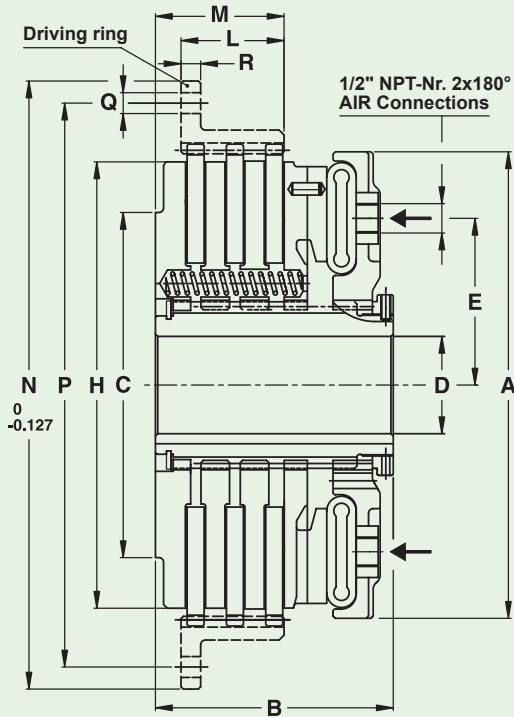

TPO 214 - TPO 318

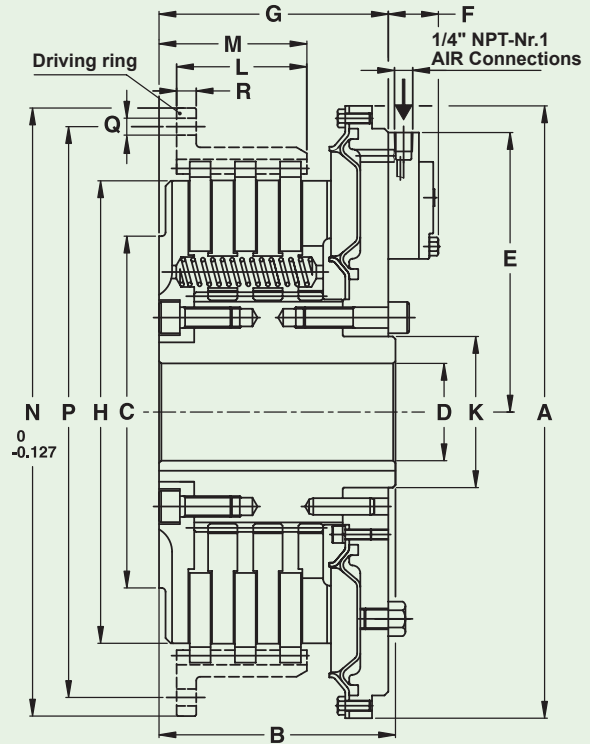

Tab.2 - DIMENSIONS: mm (inch)

MODEL	A	B	C	D max	E	H	L	M	N	P	Q		R	Total weight			
											Nr.	Dia.		kg	lb		
208	245 (9.65)	112.5 (4.42)	152 (5.98)	65 (2.56)	84 (3.31)	203 (7.99)	36.5 (1.44)	50.5 (1.98)	285.75 (11.25)	260.3 (10.25)	6	10.3 (0.41)	9.5 (0.37)	23	50.69		
308		134 (5.27)					60.3 (2.37)	72 (2.83)								30	66.12
210	307 (12.09)	120.4 (4.74)			108 (4.25)	254 (10.00)	47.6 (1.87)	56.4 (2.22)	336.55 (13.25)	317.5 (12.5)	8					35	77.14
310		142.2 (5.60)					60.3 (2.37)	78 (3.07)									

MODEL	A	B	C	D max	E	F	G	H	K	L	M	N	P	Q		R	Total weight		
														Nr.	Dia.		kg	lb	
214		146.5 (5.77)	270 (10.6)	90 (3.54)	206 (8.11)	37.6 (1.48)	142.5 (5.61)	355.6 (14.0)	116 (4.57)	67.31 (2.65)	78.5 (3.09)	466.7 (18.37)	438.2 (17.25)	8	13.5 (0.53)	12.7 (0.50)	105	235	
314	470 (18.5)	181.5 (7.15)					177 (6.97)			101.6 (4.00)	113.3 (4.46)								
318		204.5 (8.05)	385 (15.16)	110 (4.33)					199.5 (7.85)	457 (17.9)	144 (5.67)	107.9 (4.25)	129 (5.08)	571.5 (22.50)	542.9 (21.37)	6	16.7 (0.66)	15.9 (0.63)	238

DIMENSIONS ARE SUBJECT TO ALTERATION WITHOUT NOTICE

### CLUTCH SELECTION GUIDE

- The input power can be used to determine the torque limitation for the clutch:

$$T = 9550 \times kW / rpm \text{ Nm}$$

$$T = 7058 \times kW / rpm \text{ lbs-ft}$$

- to the nominal transmitted torque, it is necessary to add a service factor "S" which depends upon prime mover and type of load:

$$T_{KN} > S \times T, \text{ where } S \text{ factor is taken from table 3}$$

Tab .3 - SERVICE FACTOR S

Prime mover	Driver equipment load classification			
	light load	mod. load	mid. load	heavy load
AC electric motors	1	1.25	1.55	2.0
Multi-cylinder engines	1.25	1.5	2.0	2.5

# TPO AIR ACTUATED CLUTCHES

## OPTIONAL ACCESSORIES

ASSEMBLY WITH QUICK RELEASE VALVE  
(ONLY FOR TPO 214 - 318)

ASSEMBLY WITHOUT QUICK  
RELEASE VALVE

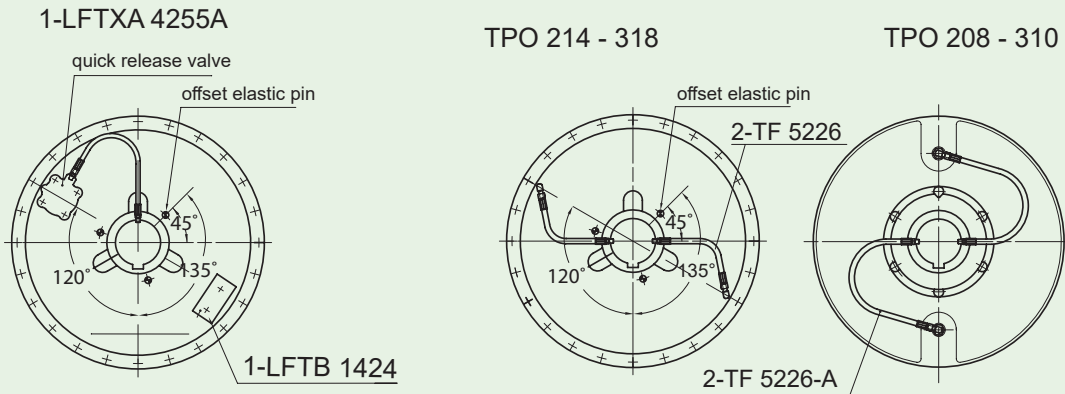

TF 5226A - TF 5226 / Less fitting adapter 1/2" - 14 NPT

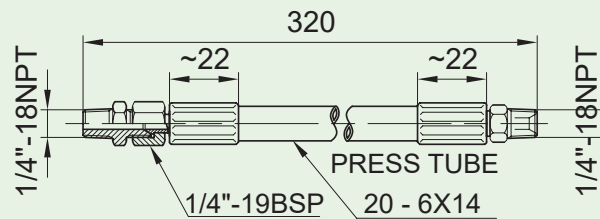
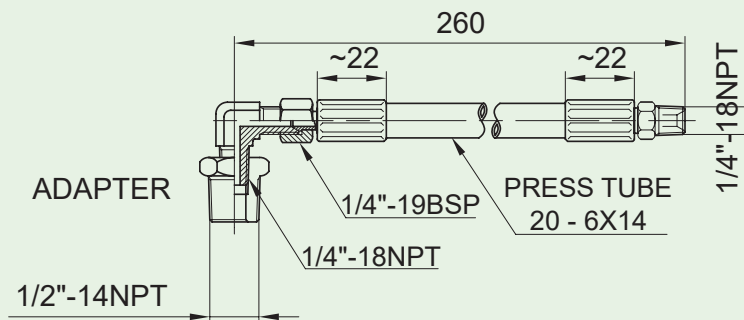

TF 6379-ER: R/H THREAD  
TF 6379-EL: L/H THREAD

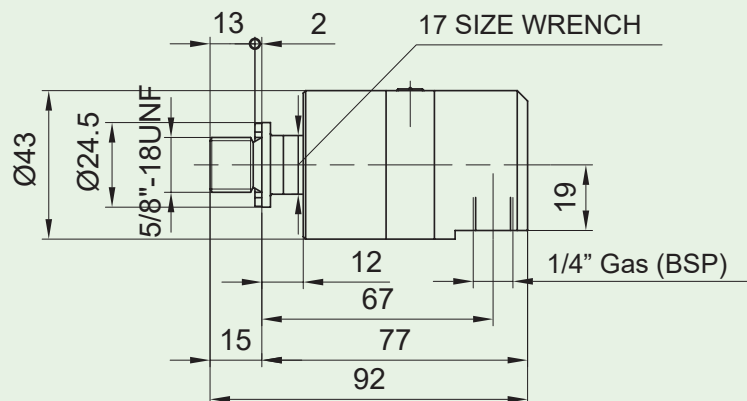

**APPLICATION EXAMPLES**

**TPO 208 - TPO 310**

**Fig.1**

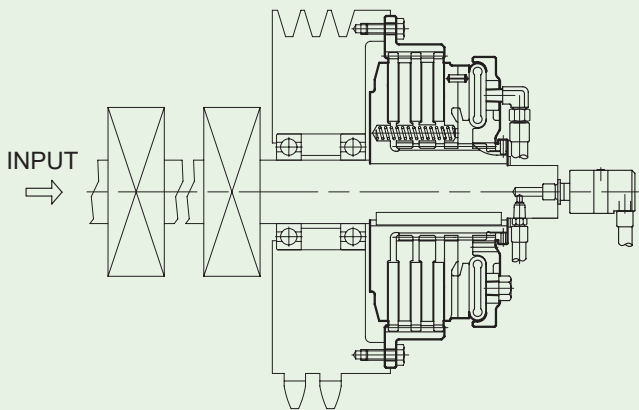

Outboard mounting

**TPO 214 - TPO 318**

**Fig.2**

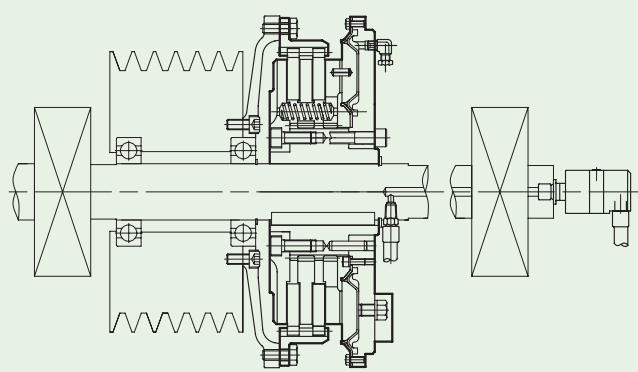

Clutch and sheave supported between two pillow blocks

**TPO 214 - TPO 318**

**Fig.3**

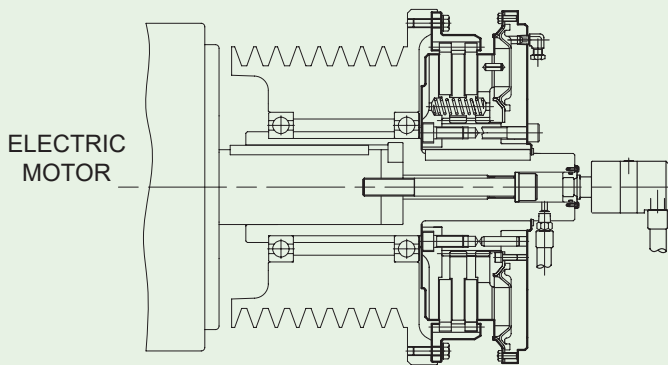

Air sheave version with sleeve fitted on EM shaft

**TPH 208 - TPH 310**

**Fig.4**

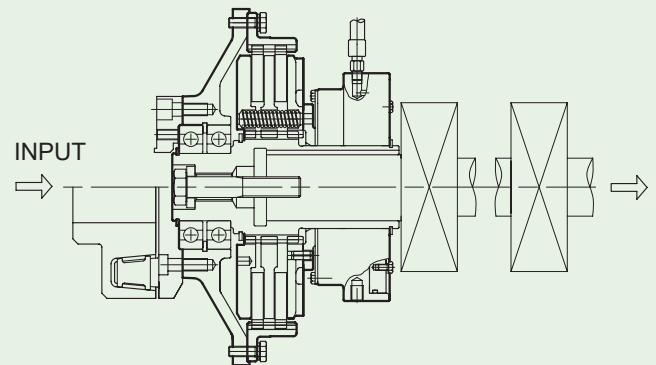

For in-line drive with flex coupling or U-joint, on input (or output)

## TPH AIR/OIL CLUTCHES

### MAIN FEATURES

The TPH model is designed for in-line drives and is based on the standard TPO clutch pack with a self-contained stationary thruster operating with 9 bar (130 Psi) air pressure.

Typically, the output is fixed and supported by the driven equipment (pump, generator, reduction gear etc). If required the input and output can be reversed.

The standard input for the TPH clutch is through the drive To simplify installation an air power-pack, 12 or 24 Vdc is ring side by a flexible coupling or a universal joint flange. available.

To simplify installation an air power-pack, 12 or 24 Vdc is available.

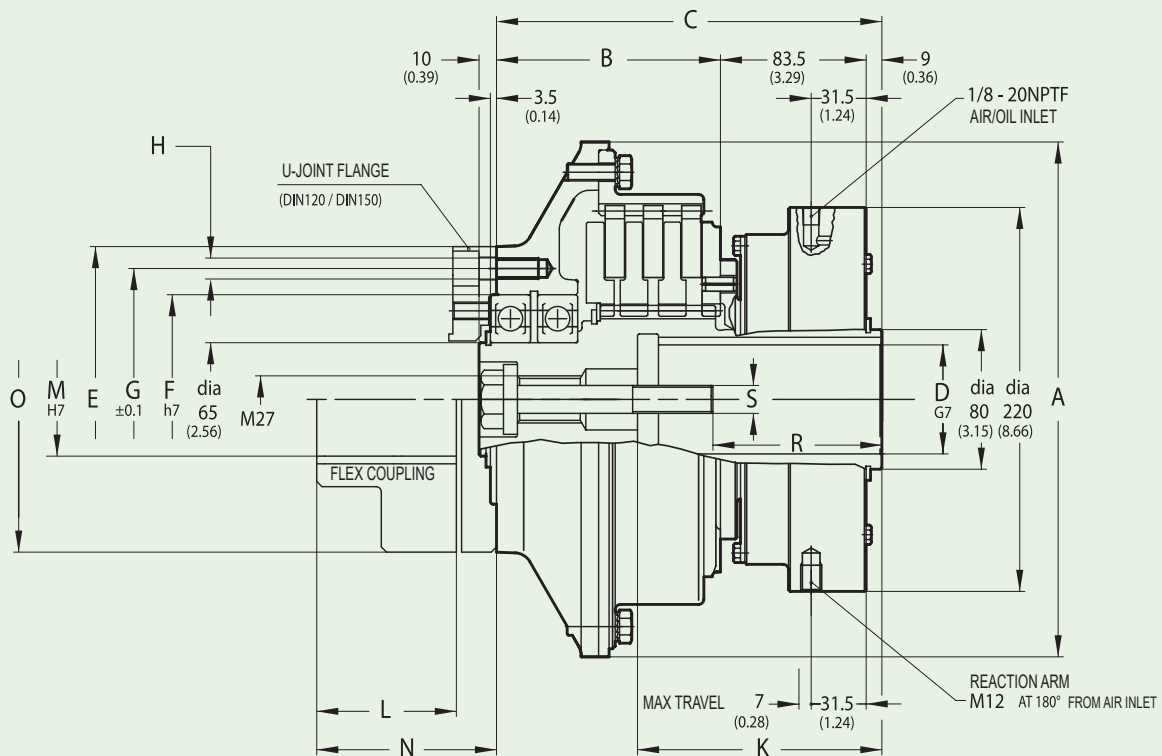

### PERFORMANCES

MODEL	Input Torque Tkn 9 bar (130Psi)		Max speed rpm
	Nm	lbs-ft	
208	815	600	3000
308	1230	901	3000
210	1000	737	3000
310	1490	1050	3000

FLEX. COUPLING							
BT 48				BT 53			
L	M max	N	O	L	M max	N	O
80 (3.15)	70 (2.76)	106 (4.17)	185 (7.28)	110 (4.33)	80 (3.15)	141 (5.55)	200 (7.87)

CLUTCH SELECTION - Refer. to tab.3 pag.2

### DIMENSIONS: mm (inch)

MODEL	A	B	C max	D max*	E	F	G	H		K max	Weight	
								Nr.	Dia.		kg	lb
208	295 (11.61)	109 (4.29)	201 (7.91)	65 (2.56)	175 (6.89)	120 (4.72)	150 (5.90)	6	M12 24 deep (0.94)	140 (5.51)	60	132.24
308		130 (5.11)	222.5 (8.76)								67	147.66
210	345 (13.58)	116.5 (4.59)	209 (8.23)								76	167.50
310		137.5 (5.41)	231 (9.09)								86	189.54

\* with reduced keyway

K, R, S depend on D bore

### U.S.A

TRANSFLUID LLC  
Auburn, GA 30011  
Ph.: +1.770.822.1777  
salesna@transfluid.us

North American website: [www.transfluid.us](http://www.transfluid.us) • Global website: [www.transfluid.eu](http://www.transfluid.eu)

TRANSFLUID S.p.A • Via Guido Rossa, 4 • 21013 Gallarate (VA) Italy • Ph. +39 0331 28421 • [info@transfluid.eu](mailto:info@transfluid.eu)