



# TRANSFLUID<sup>®</sup>

**industrial & marine**

# TRANSFLUID



**drive with us**

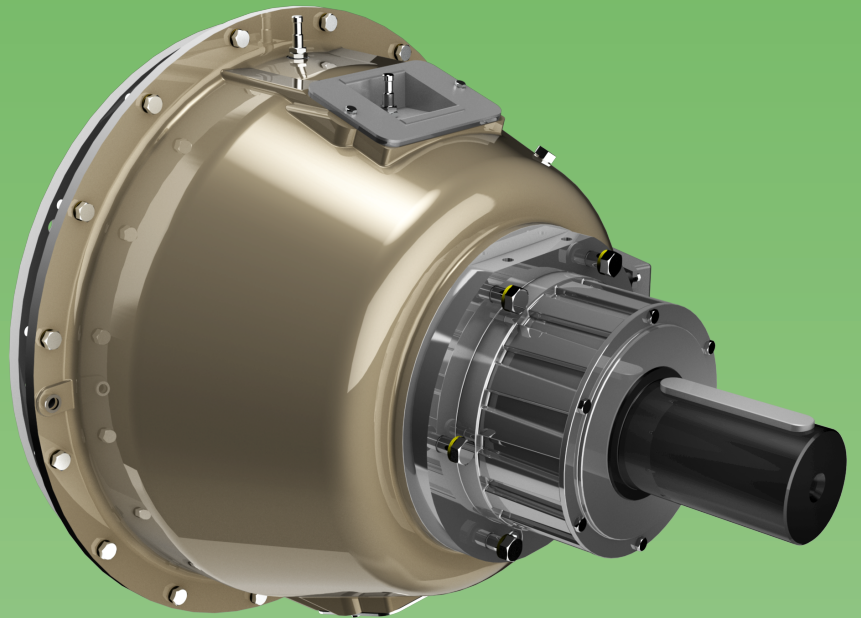

**HF - MFO**  
POWER TAKE OFF

# HF - MFO POWER TAKE OFF

**HFR** - FOR SIDE LOAD AND IN-LINE SELF SUPPORTING DESIGN  
ELIMINATES SIDE LOADS ON THE ENGINE FLYWHEEL

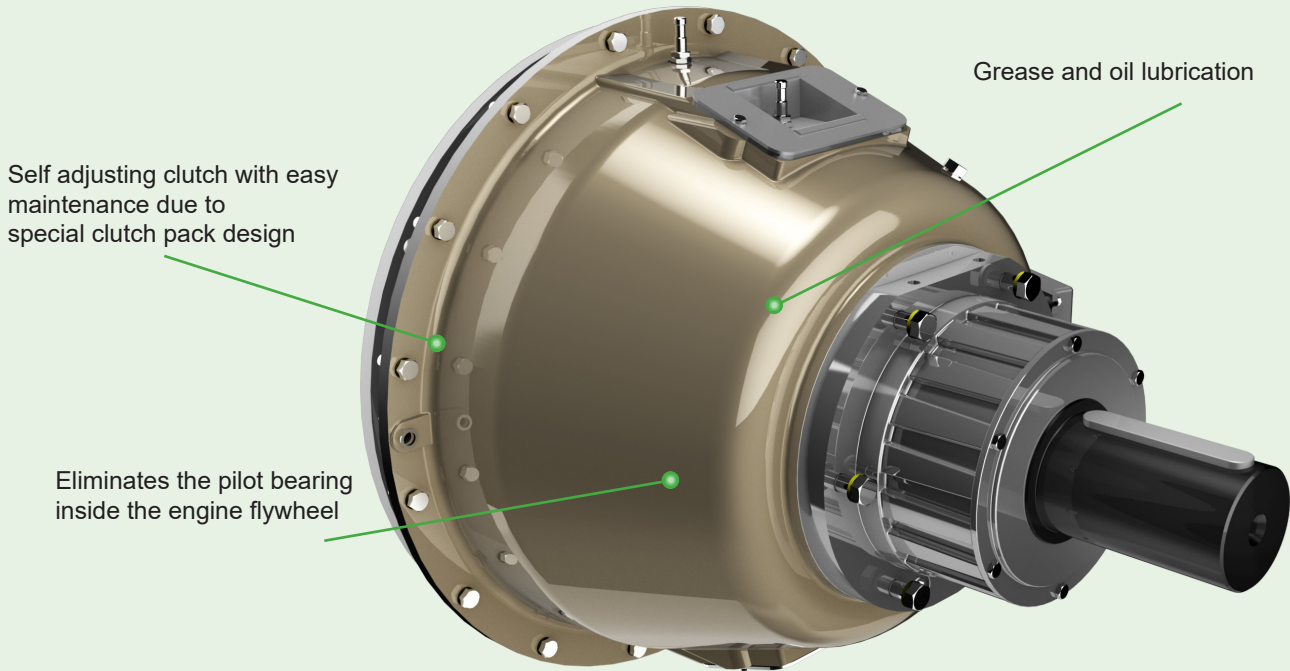

**MFO** - FOR SIDE LOAD AND IN-LINE SELF SUPPORTING DESIGN  
ELIMINATES SIDE LOADS ON THE ENGINE FLYWHEEL



## OPTIONAL:



MPCB R5



Air power pack  
up to - 5°C

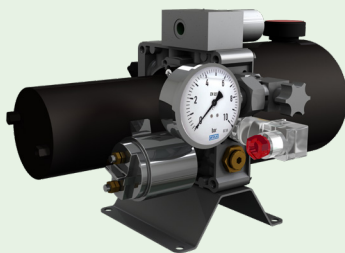

Oil power pack

## OIL / AIR ACTUATION

- remote control operation by push button engagement
- self adjusting; no operator adjustment required

## UNIQUE CLUTCH DESIGN

- compact design
- high torque capacity
- eliminates the engine flywheel pilot bearing (HFO)
- no side load on flywheel (HFR and MFO)
- SAE standard interface
- dust proof for harsh environmental conditions
- simplified service in case of disc replacement
- easy installation
- Kevlar friction discs (with the exception of HFR210) for heavy duty and torsionally active applications, standard discs available

## MFO

The **MFO** mechanical power take-off consists of a lever actuated clutch with a shaft and bearings mounted in a rigid cast housing. It is designed for inline and sideload applications for internal combustion engines with standard SAE industrial flywheel/flywheel housing dimensions.

MFO mechanical power take-offs will allow:

- to simplify installation time (no pilot bearing alignment required)
- to increase uptime and engine life
- to reduce inventory

## HFO - FOR SIDE LOAD APPLICATIONS

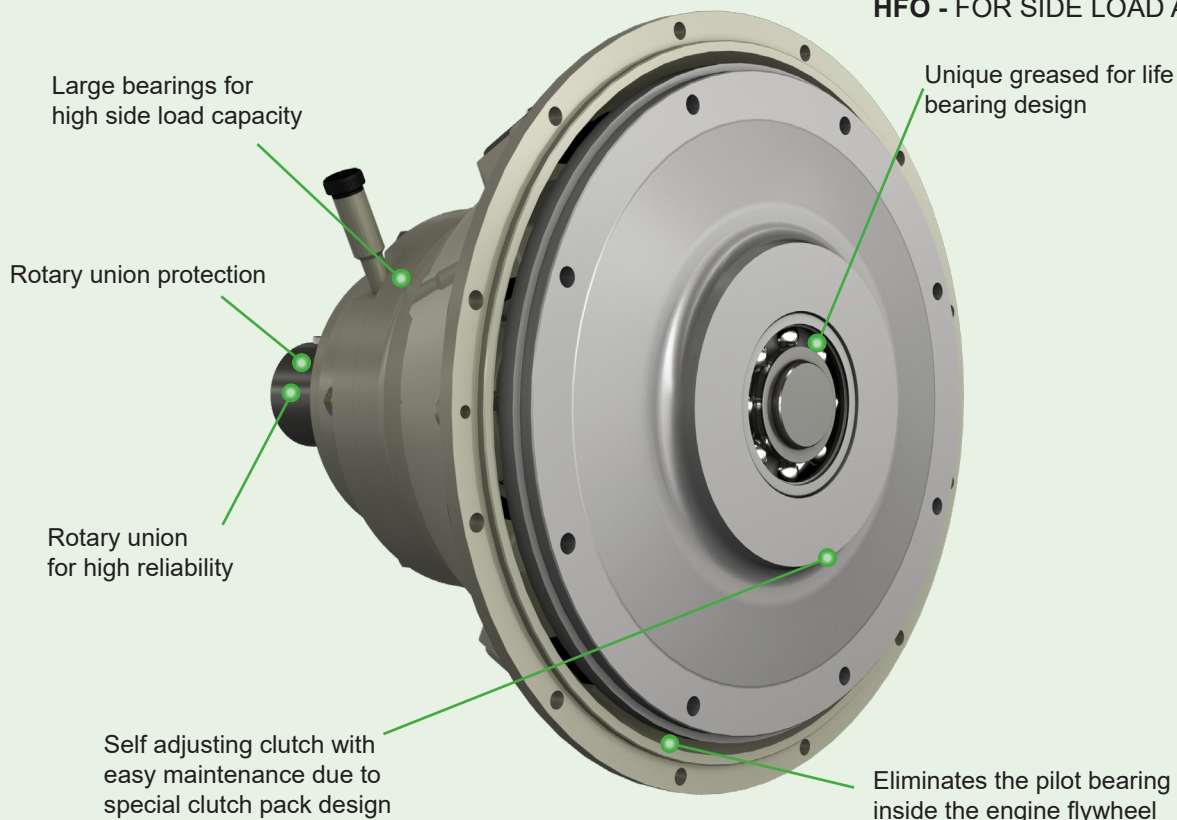

# HFR - POWER TAKE OFF

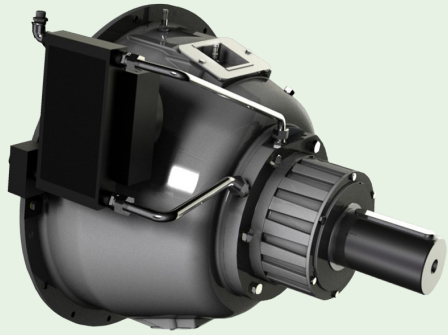

## HFR OIL/AIR ACTUATED POWER TAKE OFF

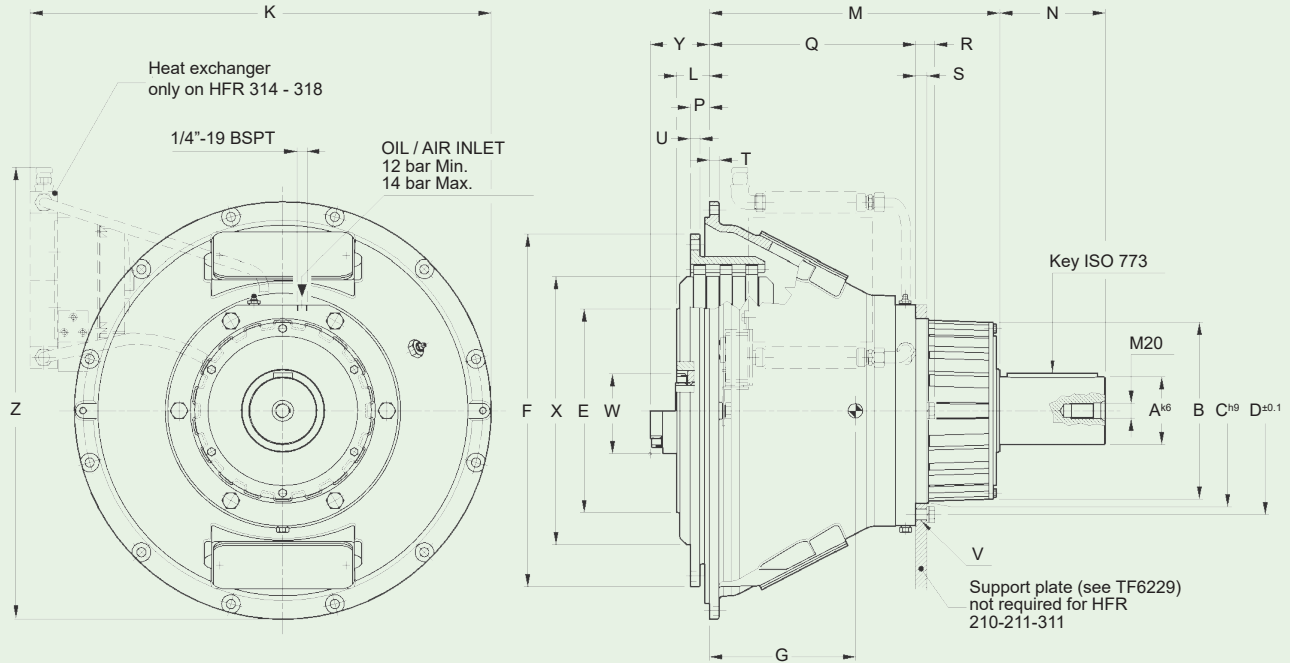

Dimensions																								
SIZE	SAE Housing size	SAE Flywheel size	A	B	C	D	E	F	L	M	N	P	Q	R	S	T	U	V		X	Y	W	K	Z
																		Ø	Nr.					
210	4	10"	60	155	-	-	90	314.3	63	220	110	53.8	-	-	-	11	47	-	-	254	83	70	-	-
211	3-2	11 1/2"																						
311	3-2-1		80	177	223.5	352.4	49.5	280	140	25.4	273.3	27	15	12.7	12.7	15	6X60°	355	45.2	75	650	563		
314	1-0	14"	90	234	245	275	270	466.7	43.2	384.8	140	25.4	273.3	27	15	12.7	12.7	15	6X60°	355	45.2	75	650	563
318	0	18"	110	258	265	305	385	571.5	40	515	180	15.7	380	32	18	14	16	17	6X60°	457	45	85	810	662

Technical data							
SIZE	MAX SPEED rpm	MAX INPUT TORQUE KEVLAR (at 12 bar) Nm (ft/lbs)	MAX INPUT TORQUE STANDARD (at 12 bar) Nm (ft/lbs)	THERMAL CLUTCH CAPACITY Q	OUTPUT BEARING LUBRICATION	WEIGHT kg	CENTER OF GRAVITY G dimension
210	2800	-	1300 (958)	517	Grease	63	48
211	2800	1400 (1032)	-	514	Grease	78	54
311	2800*	2250 (1659)	1700 (1253)	747	Grease	127	84
314	2100	4900 (3614)	3600 (2655)	1128	Oil	206	137
318	2100	7750 (5694)	-	1980	Oil	368	155

- For permissible radial loads see selection instructions  
 - Dimensions are subject to alteration without notice  
 \* For inline applications with radial load, the limit decreases

## HFO - MFO POWER TAKE OFF

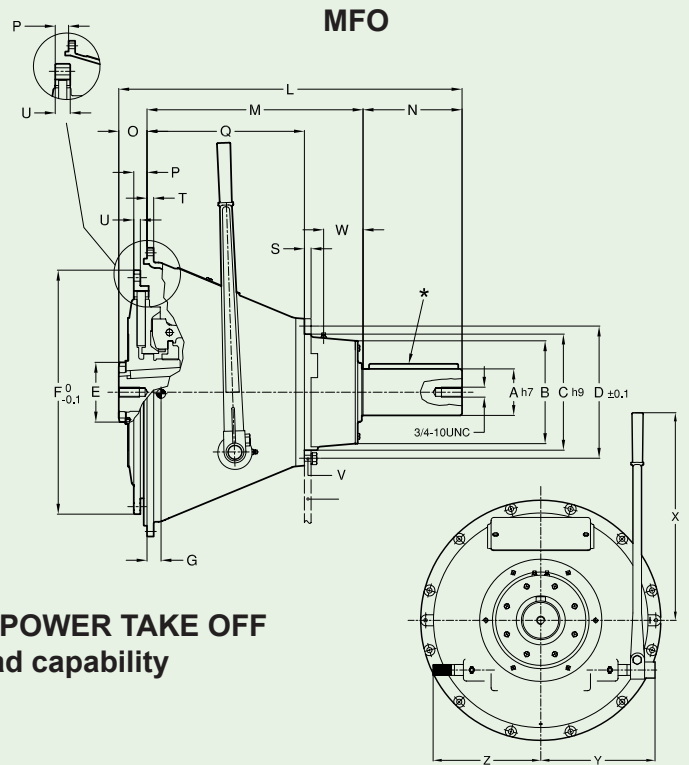
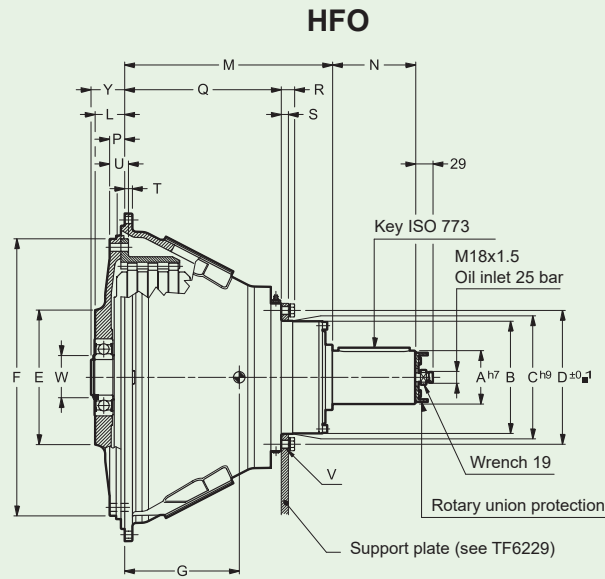

### HFO OIL ACTUATED POWER TAKE OFF High radial load capability

Dimensions																						
SIZE	SAE Housing size	SAE Flywheel size	A	B	C	D	E	F	L	M	N	P	Q	R	S	T	U	V		W	X	Y
																		Ø	Nr.			
314	1-0	14"	90	236	245	275	225.5	466.7	49.9	350.3	140	25.4	273.3	27	15	12.7	31.7	15	6x60°	73.4	-	56.8

Technical data							
SIZE	MAX SPEED rpm	MAX INPUT TORQUE KEVLAR (at 25 bar) Nm (ft/lbs)	MAX INPUT TORQUE STANDARD (at 25 bar) Nm (ft/lbs)	THERMAL CLUTCH CAPACITY Q	OUTPUT BEARING LUBRICATION	WEIGHT kg	CENTER OF GRAVITY G dimension
314	2400	4900 (3614)	3600 (2655)	1128	Grease	167	130

- For permissible radial loads see selection instructions  
- Dimensions are subject to alteration without notice

## MFO: MECHANICAL POWER TAKE OFF

Dimensions																							
SIZE	SAE Housing size	SAE Flywheel size	A	B	C	D	E	F	L	M	N	O	P	Q	S	T	U	V		W	X	Y	Z
																		Ø	Nr.				
MFO110	4	10"	57.1	146	165.1	-	58	314.3	415.9	251.6	96.8	67.5	53.8	159.4	9.53	11.1	22.2	-	-	66.8	314	255.6	247.6
MFO111	3	11½"	57.1	146	158.7	184.1	58	352.4	466.2	300.7	101.6	63.9	39.6	183.4	12.7	11.1	22.2	6	9	96.3	314.9	255.6	247.6
MFO114	1	14"	76.2	171.4	190.5	222.2	85	466.7	530.7	348.4	128.3	54.1	25.4	250.8	12.7	12.7	12.7	6	13.5	65.9	476.5	263.7	247.6
MFO214			88.9	196.8	222.2	251.6	85		656.8	413.5	189.3	54.1		403.1	12.7	12.7	12.7	6	13.5	75.4	477.2	254.8	247.6

Technical data					
SIZE	CENTER OF GRAVITY G dimension	MAX SPEED rpm	MAX INPUT TORQUE KEVLAR Nm (ft/lbs)	MAX INPUT TORQUE STANDARD Nm (ft/lbs)	WEIGHT kg
MFO110	78	2800	-	610 (449)	56
MFO111	86	2500	1000 (737)	770 (567)	74
MFO114	111	2300	-	2050 (1512)	125
MFO214	148	2300	-	4050 (2987)	167

- Dimensions are subject to alteration without notice

# HF – MFO POWER TAKE OFF

## HFR

### oil/air supply 12 bar in-line and side load application

The HFR clutches have been designed to complete the TRANSFLUID range of power take offs for new potential markets. The oil-air actuation is provided by oil or air radial inlet instead of axial as the HFO: this configuration permits the mounting of couplings and/or cardan shafts on the output shaft. The actuation oil or air is controlled externally and enters the clutch radially directly into the bearing carrier.

### Control and management of the HFO-HFR equipment:

- By customer hydraulic circuit
- By MPCB R5 with hydraulic control block, through continuous monitoring of some parameters proper transmission operation is assured. Any abnormal condition is promptly detected and countermeasures quickly enforced to protect the transmission as well as the engine
- By oil/air power pack: a compact power system which delivers either oil or air with suitable pressure
- By MPCB R5 with oil power pack only for HFO

## HFO

### oil supply 25 bar side load application

The HFO clutches have been developed by TRANSFLUID to meet the growing market demand for power take offs applied to high speed, high horse power industrial engines and remote control operation.

The HFO consists of an oil actuated clutch assembly (dry plates) with a shaft and bearings suitable for high side loads mounted in a cast iron housing that provides easy engine installation.

The clutch actuation is provided by a rotating union mounted in the output shaft .

This system allows the use of HFO for belt driven applications only. The oil actuation permits remote control as well as a larger transmittable torque compared to the traditional overcenter PTOs. In addition, due to the continuous pressure applied to the clutch plates, the HFO is a self adjusting clutch which drastically reduces the maintenance costs especially on heavy duty applications where plate wear is typical.

Additional to the HFO is the HFF design (flanged shaft by QD).

This model is designed for road milling machines where a compact layout is required.

## MFO

- No installation related engine thrust bearing damage
- Equipment with ball-bearing engagement collars
- No direct loading to engine crankshaft enhances life of engine bearings
- Dual spherical roller main bearing design
- Driving rings are nodular iron or steel

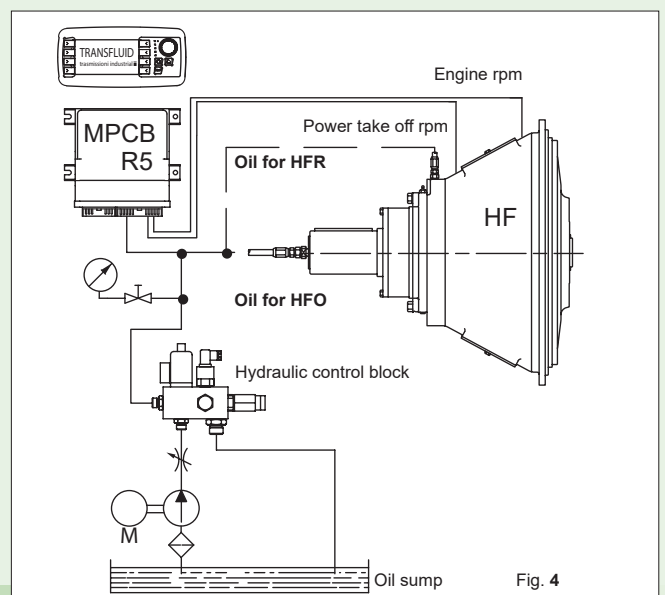
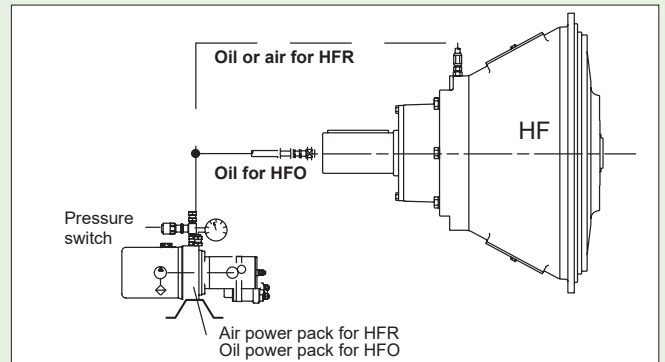
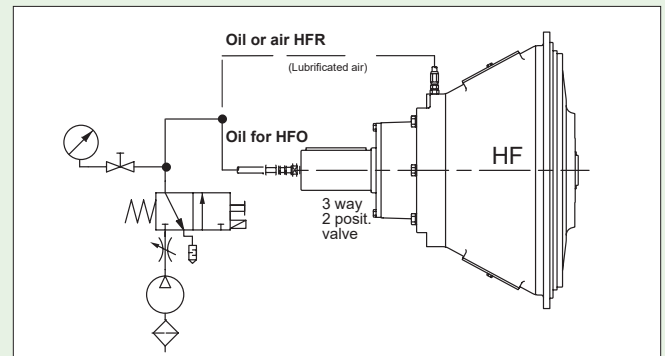
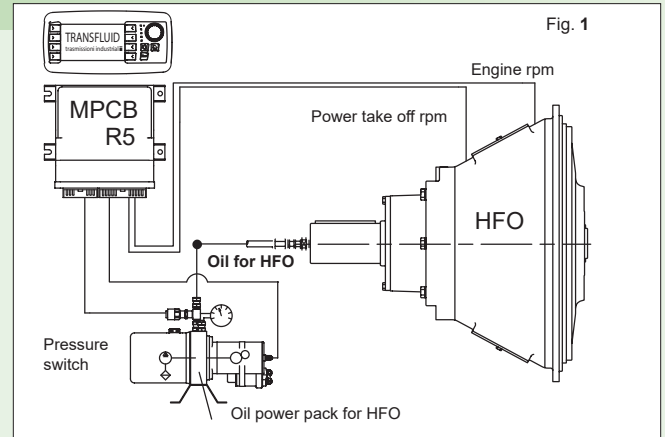

### SELECTION GUIDE

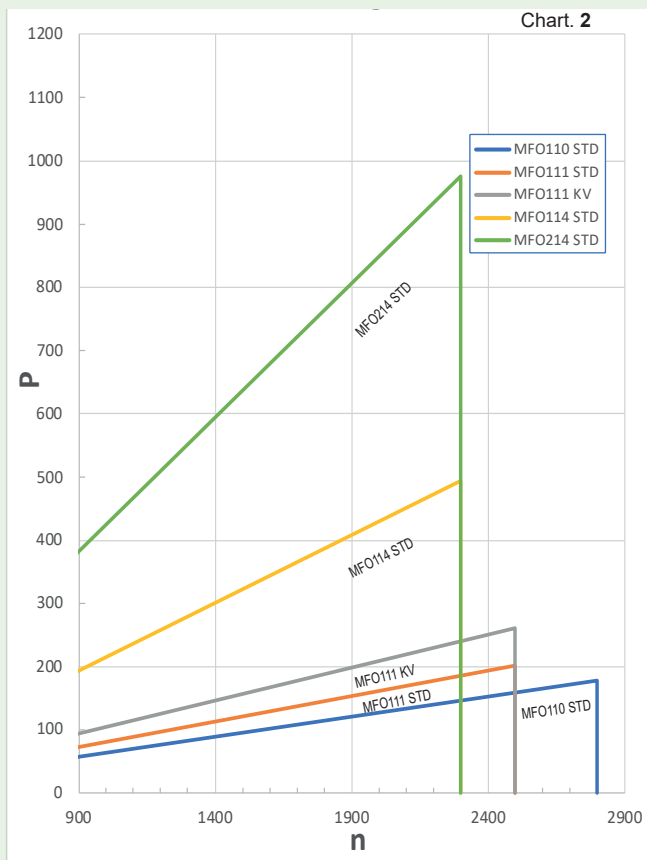
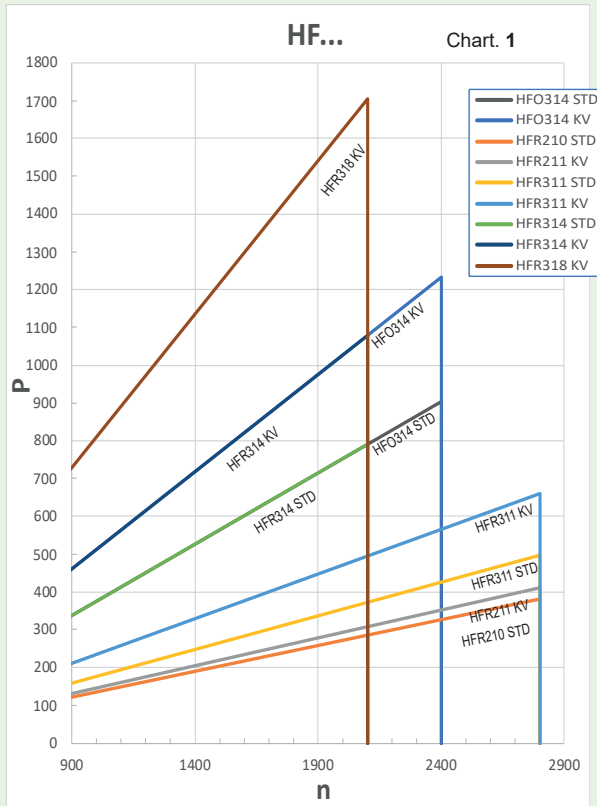

Tab. 1

APPLICATION FACTOR F*	PRIME OVER				Driven machine load classification
	Multi cylinder Internal combustion engine		Multi cylinder Internal combustion engine with high torque rise		
	Up 10 hours/day	Over 10 hours/day	Up 10 hours/day	Over 10 hours/day	
1.25	1.5	1.75	2	Uniform load	
1.5	1.75	2	2.25	Moderate shock	
2	2.25	2.5	2.75	Heavy shock 1	
2.25	2.5	2.75	3	Heavy shock 2	

\* According to AGMA standard

#### STEP 1 - QUICK SELECTION

- Uniform load: fluid coupling, marine propulsion, fan, centrifugal pump, compressor, generator, water jet.
- Moderate shock: road milling machine, cone crusher, volumetric pump, snow blower, drill, pump for dredge.
- Heavy shock 1: jaw crusher, impactor, wood chipper, shredder, grinder, hammer mills.
- Heavy shock 2: reciprocating compressor, piston pumps.

F : application factor (see Tab. 1)

kW : gross engine power (kW)

n : speed (rpm)

$$P = kW \cdot F$$

- PTO engagement must be performed at approximate engine idling speed.
- Interval between starts should be 1 hour minimum (fluid coupling mounted on the PTO output shaft allows 3 starts/hour evenly spaced).
- For other technical information, consult the Installation and Maintenance Manual.

#### KEVLAR FRICTION DISCS:

For heavy duty and torsionally aggressive applications, the use of Kevlar discs is recommended.

For side load applications HFR with Kevlar discs must be used.

#### STEP 2 - THERMAL CAPACITY VERIFICATION

T : max input torque (Nm) - see table pages 3 & 4

J : inertia (kgm<sup>2</sup>) = GD<sup>2</sup> / 4

t : starting time (seconds) - actual slip

Q : thermal clutch capacity - see table pages 3 & 4

$$t = \frac{J \cdot n}{9.55 \cdot T}$$

$$kW \cdot t \leq Q$$

In case of higher Q value than stated in the technical data table (see pages 3 & 4), size of the clutch has to be revised.

0.746 kW = 1 hp

25.4 mm = 1 inch

0.042 kgm<sup>2</sup> = 1 lbs · ft<sup>2</sup>

1.356 Nm = 1 lbs · ft

### STEP 3 - PERMISSIBLE SIDE LOAD CHART 3

- Calculated bearing life over 5000 hours
- Rim speeds over 35 m/s, the dynamic balancing of the pulley is recommended
- Timing belts must be approved by TRANSFLUID
- "X" distance is according to belt type & number

#### Actual applied side load "T"

$$(a) T [kN] = \frac{S \cdot kW \cdot L \cdot 191 \cdot 100}{D \cdot n}$$

D : pulley pitch diameter (mm)  
 kW : gross engine power (kW)  
 n : (rpm)  
 S : service factor  
 L : life factor

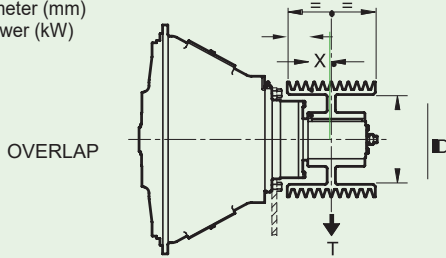

#### IMPORTANT NOTICE

- Disregarding system torsional compatibility could cause damage to components in the drive train resulting in loss of mobility or power transmission. At minimum, system torsional incompatibility could result in unwanted noise and vibration at low speeds.
- The responsibility for ensuring that the torsional load of the system is satisfactory rests with the assembler of the drive and driven equipment.
- The acceleration of large inertial loads may require special applications or downsizing of the intended units. TRANSFLUID is prepared to assist in finding solutions to potential inertial problems that relate to the power take-off.

Selection of HFR/HFO/MFO based on permissible side load:

- Calculate side load with formula (a).
- Enter side load and X distance.
- Select clutch.

#### EXAMPLE:

T side load= 65 kN  
 X distance = 30 mm  
 select HFO 314

- Clutch reference speed in Chart 2 is 2100 rpm.
- If the engine speed is higher than above indicated value, contact TRANSFLUID for application approval.

Service Factor	S
Chain or gear drive	1.0
V-Belts	2.2

Life Factor	L
Cyclic and shock loads	2.1
High-medium side load	1.8
Low side load	1.2
Medium-low side load (hydraulic belt tensioner)	0.9

Tab. 2

HFO	Max overlap allowable* [mm]	Min pulley ID* [mm]
314	50	245

Tab. 3

HFR	Max overlap allowable* [mm]	Min pulley ID* [mm]
210	71	155
211	71	155
311	83	177
314	83	233
318	102	263

Tab. 4

MFO	Max overlap allowable* [mm]	Min pulley ID* [mm]
110	55	165
111	85	160
114	55	190
214	60	220

\* Dimensions are limits. Space for rotating parts must be added.

#### PERMISSIBLE SIDE LOAD T vs DISTANCE X Chart 3

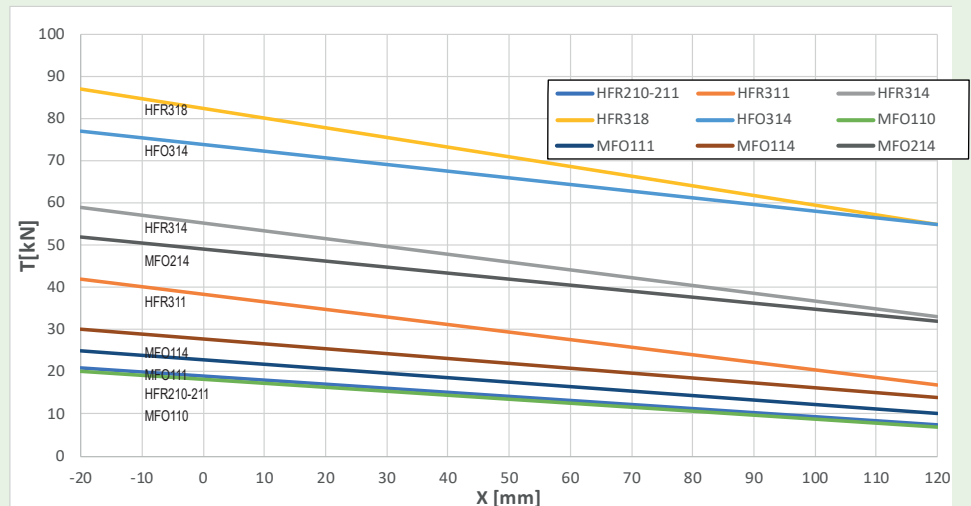

Global website: [www.transfluid.eu](http://www.transfluid.eu) • North American website: [www.transfluid.us](http://www.transfluid.us)

#### U.S.A

TRANSFLUID LLC  
 Auburn, GA 30011  
 Ph.: +1.770.8221.777  
[salesna@transfluid.us](mailto:salesna@transfluid.us)