

**Bellmarine**<sup>®</sup>  
powered by Transfluid



**ELECTRIC PROPULSION SYSTEMS**



**TRANSFLUID**  
industrial & marine

# Intro

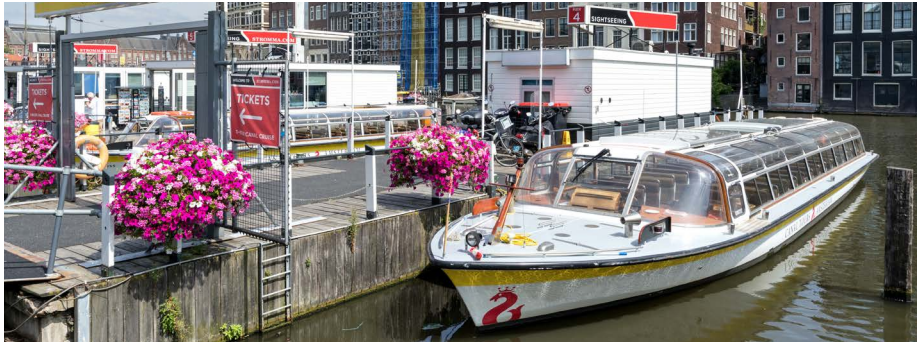

## Electric boating starts at Bellmarine.

In the world of electric propulsion systems, Bellmarine sets the standard. Years of experience, quality, innovation and reliability are a guarantee for pure boating, work and pleasure.

## Perfection in every detail

All parts installed below deck have to be of the highest quality, because moisture and salt will take their toll and have effect on the durability of your drive system. Only the best materials are suitable and each have been carefully selected by Bellmarine.

## E-motion in propulsion

The Bellmarine systems are developed and produced in Italy and in the Netherlands. With thousands of electric propulsion systems in use, Bellmarine is now the benchmark. You are guaranteed the highest quality and service.

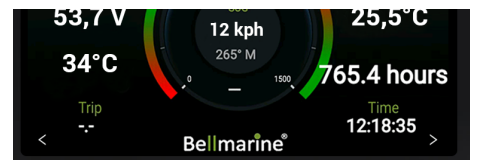

# Index





Product	Page:
Certificates	4
Master Info	6
DriveMaster	6
ModularMaster	8
TorqueMaster	9
ShaftMaster	10
SternMaster	11
DriveMaster & ShaftMaster 260W	12
SternMaster 130W & SternMaster 260W	13
SailMaster	14
SquidMaster	16
OutboardMaster	18
Accessories	19
Lever	19
Cooling system	21
Propeller shaft assembly	22
Optional kits	22
Display	23
Battery	24
Battery Charger	25
Inverter & DC-DC converter	26



- All images are for reference only
- All data can be changed without notice

# Certificates

## Batteries

 <p>Our battery System successfully passed all the DNV-GL tests including the new 2018 forced thermal runaway and this makes it compliant with Norwegian Maritime Authority (NMA) Propagation Test 1</p>	 <p>All Bellmarine Systems are compliant with the European Standard Technical Requirements for Inland Navigation vessels (ES-TRIN)</p>	 <p>Sjøfartsdirektoratet Norwegian Maritime Authority</p>  <p>Maritime &amp; Coastguard Agency</p>	 <p>BUREAU VERITAS 1828</p>  <p>BUREAU VERITAS</p>
---	---	---	--

## Electric Motors

 <p>DNV.COM/AF</p>	 <p>All Bellmarine Systems are compliant with the European Standard Technical Requirements for Inland Navigation vessels (ES-TRIN)</p>	 <p>BUREAU VERITAS 1828</p>  <p>BUREAU VERITAS</p>
---	---	--

## Motor Controllers

<p>Only for 307V and 409V</p>  <p>DNV.COM/AF</p>	 <p>All Bellmarine Systems are compliant with the European Standard Technical Requirements for Inland Navigation vessels (ES-TRIN)</p>
---	---

## Work in progress

*KOMSA (South Korea)*  
Approval work in progress



# Master Info

- 1 - All motors are Permanent Magnets AC, high efficiency, IP65
- 2 - Intermittent kW: S3 10% - 10' (1 minute at intermittent power then reduced for 9 minutes to return to stable temperature)
- 3 - Batteries can be of any chemistry and brand.

TF BATTERY	min [Vdc]	max [Vdc]
51	44	59
102	88	118
140	121	162
307	264	355
409	352	473

To evaluate the battery characteristics in case of customer's supply please use the following formula giving the max (A) current required by Transfluid's motors:

$$I (A) = \frac{kW \times 1000}{V} \times 2$$

#### 4 - RATINGS:

- Cruising speed: 70% of rated motor rpm
- Light Duty: air cooled motor, up to 200 hours/year, intermittent kW allowed
- Medium Duty: air cooled motor, up to 500 hours/year, only nominal kW allowed
- Medium Duty: liquid cooled motor, up to 1000 hours/year, intermittent kW allowed
- Heavy Duty: liquid cooled motor, up to 3000 hours per year, intermittent kW allowed, max 80% of time at rated rpm and load

5 - For Torque calculation use the formula:

$$T (Nm) = \frac{kW}{rpm} \times 9550$$

# DriveMaster

Permanent magnet motors for installation on shaft lines; available with air or liquid cooling.  
Maximum efficiency, silent and compact solution. Regeneration via dragged propeller possible.

## Air Cooled

#### Including:

- Motor with mounting brackets and silent blocks
- Motor with integrated thrust bearing (max 20kW)
- Vector control inverter IP65
- Precharge circuit
- DC-DC converter 12 Vdc
- 5m cable for display, lever, key
- Quick install / easy connect / plug and play
- key panel (OFF-ON-ECO)

#### Optional:

- Main switch and main fuse (Only for 48/96/144Vdc battery w/o internal switch and fuse)
- TFEasy display NMEA2000
- Drop box DP280 (ratio i= 1.59 - 2.01 - 2.41 - 2.87 - 3.35 - 3.97 - 5.01)
- Regeneration kit (Cable + key panel ON-OFF)

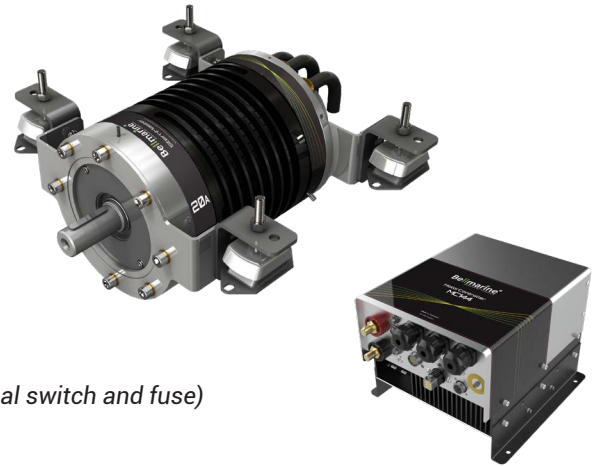

( ) Transfluid battery  
• Complete the scope of supply with accessories from p. 19

PRODUCT CODE	DESCRIPTION	MOTOR SIZE	Light & Medium Duty		BATTERY Vdc	MOTOR rpm
			NOMINAL hp	INTERMITTENT hp		
BV101489A	DriveMaster 2A	180-4	2	2	48 (51)	1500
BV100854A	DriveMaster 5A	180-8	5	6		
BV101529A	DriveMaster 7A	180-12	6	9		
BV101808A	DriveMaster 10A	220-20	10	13	96 (102)	1500
BV102008A	DriveMaster 8A	180-12	8	10		
BV102015A	DriveMaster 15A	220-20	13	20		
BV101288A	DriveMaster 25A	220-35	26	33	144 (140)	1500
BV102035A	DriveMaster 35A	300-50	40	46		
BV102050A	DriveMaster 50A	300-75	53	67		

# DriveMaster

## Liquid Cooled

### Including:

- Motor with mounting brackets and silent blocks
- Motor with integrated thrust bearing (max 20kW)
- Vector control inverter IP65
- Precharge circuit
- DC-DC converter 12 Vdc
- 5m cable for display, lever, key
- Quick install / easy connect / plug and play
- Inlet and outlet liquid connections
- key panel (OFF-ON-ECO)

### Optional:

- Main switch and main fuse (Only for 48/96/144Vdc battery w/o internal switch and fuse)
- TFEasy display NMEA2000
- Drop box DP280 (ratio  $i = 1.59 - 2.01 - 2.41 - 2.87 - 3.35 - 3.97 - 5.01$ )
- Regeneration kit (Cable + key panel ON-OFF)



PRODUCT CODE	DESCRIPTION	MOTOR SIZE	Medium & Heavy Duty		BATTERY Vdc	MOTOR rpm
			NOMINAL hp	INTERMITTENT hp		
BV101608W	DriveMaster 3W	180-4	3	4	48 (51)	1500
BV100854W	DriveMaster 7W	180-8	6	9		
BV100808W	DriveMaster 10W	180-12	10	13		
BV100810W	DriveMaster 15W	220-20	13	20		
BV101610W	DriveMaster 20W EVO	220-20 (s)	20	26	96 (102)	
BV100812W	DriveMaster 20W	220-20	20	26		
BV101288W	DriveMaster 30W	220-35	33	40	144 (140)	
BV101642W	DriveMaster 45W	300-50	46	60		
BV101580W	DriveMaster 55W	300-75	60	73		

(s) Special  
( ) Transfluid battery

• Complete the scope of supply with accessories from p. 19

# ModularMaster

Pair of permanent magnet motors, liquid-cooled and parallel assembled for high power with low voltage. Ideal for anyone requiring system redundancy with flexible installation and compactness.

## Liquid Cooled

with SPD11 Split Power Drive

### Including:

- True redundancy in case of one motor failure
- Aluminum made split power drive
- Mounting brackets and silent blocks
- Live PTO available
- Vector control inverters IP65
- Precharge circuit
- DC-DC converter 12 Vdc
- 5m cable for display, lever, key
- Quick install / easy connect / plug and play
- Inlet and outlet liquid connections
- Closed loop liquid cooling mounted aboard
- Key panel (OFF-ON-ECO)
- Throttle lever TFC
- TFEasy display NMEA2000

### Optional:

- Main switch and main fuse (Only for 48/96/144Vdc battery w/o internal switch and fuse)
- Drop box DP280 (ratio  $i = 1.59 - 2.01 - 2.41 - 2.87 - 3.35 - 3.97 - 5.01$ )

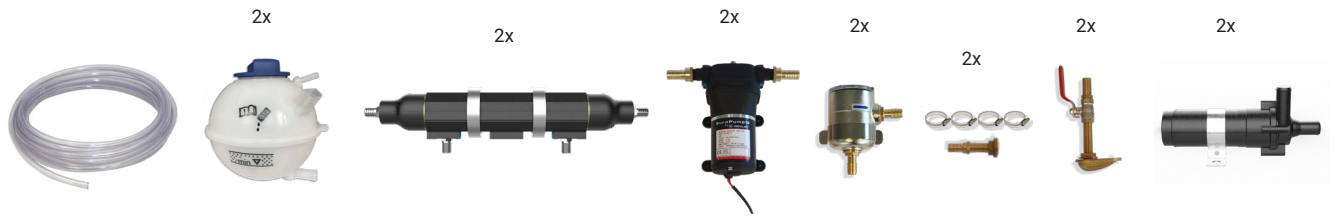

PRODUCT CODE	DESCRIPTION	MOTOR SIZE	Medium & Heavy Duty		BATTERY Vdc	MOTOR rpm
			NOMINAL hp	INTERMITTENT hp		
BV201450W	ModularMaster 40W EVO	2x220-20 (s)	40	53	48 (51)	1500
BV101485W	ModularMaster 40W	2x220-20	40	53	96 (102)	
BV101480W	ModularMaster 60W	2X220-35	67	80	144 (140)	

(S) Special  
 ( ) Transfluid battery  
 \* For twin screw application ask for appropriate product code

• Complete the scope of supply with accessories from p. 19

# TorqueMaster

Permanent magnet motors with a mechanical reducer with various gear ratios; available with air or liquid cooling. A compact solution designed to couple to any propeller.

## Air Cooled

reduction ratio  $i = 1.59 - 2.01 - 2.41 - 2.87 - 3.35 - 3.97 - 5.01$

Propeller rpm = motor rpm/i

### Including:

- Motor with mounting brackets and silent blocks
- Drop Box - 225 mm offset
- Vector control inverter IP65
- Precharge circuit
- DC-DC converter 12 Vdc
- 5m cable for display, lever, key
- Quick install / easy connect / plug and play
- Drop Box aluminum made - no cooling needed - low noise and low vibration
- Oil temperature sensor
- Elastic coupling between motor and Drop Box
- DIN120 output (SAE 1410 upon request) - "U" drive possible
- Key panel (OFF-ON-ECO)

### Optional:

- Main switch and main fuse (Only for 48/96/144Vdc battery w/o internal switch and fuse)
- TFEasy display NMEA2000
- Regeneration kit (Cable + key panel ON-OFF)
- "U" drive

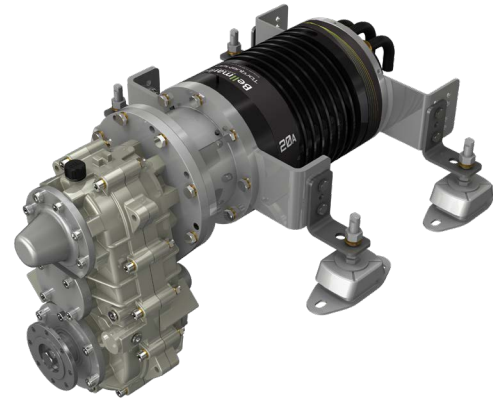

PRODUCT CODE	DESCRIPTION	MOTOR SIZE	Light & Medium Duty		BATTERY Vdc	MOTOR rpm
			NOMINAL kW	INTERMITTENT kW		
BV101716A ...	TorqueMaster 20A	220-20	20	26	96 (102)	3000
BV102025A ...	TorqueMaster 25A	220-20	26	33	144 (140)	3000

(...) According to reduction ratio  
( ) Transfluid battery

## Liquid Cooled

reduction ratio  $i = 1.59 - 2.01 - 2.41 - 2.87 - 3.35 - 3.97 - 5.01$

Propeller rpm = motor rpm/i

### Including:

- As above
- Inlet and outlet liquid connections
- ▲ Throttle lever TFC - DC-DC converter 24 Vdc - Key panel (OFF-ON) Electric box (500x500mm) and wiring

### Optional:

- As above

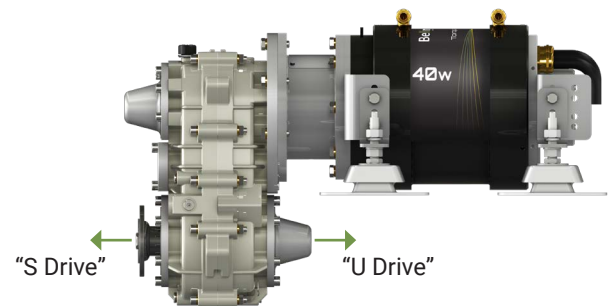

PRODUCT CODE	DESCRIPTION	MOTOR SIZE	Medium & Heavy Duty		BATTERY Vdc	MOTOR rpm
			NOMINAL hp	INTERMITTENT hp		
BV101740W ...	TorqueMaster 20W EVO	220-20 (s)	20	26	48 (51)	1500
BV101716W ...	TorqueMaster 25W	220-20	26	33	96 (102)	3000
BV101717W ...	TorqueMaster 35W	220-20	40	46	144 (140)	
BV102045W ...	TorqueMaster 45W	220-35	46	60	288 (307)	
BV102065W ...	TorqueMaster 65W	300-50	67	87		
BV102100W ...	TorqueMaster 100W	300-75	100	134		
BV102130W ...	TorqueMaster 130W	300-75	134	174	384 (409)	

(...) According to reduction ratio  
(S) Special  
( ) Transfluid battery

• Complete the scope of supply with accessories from p. 19

# ShaftMaster

Permanent magnet motors with powershift marine gear with various gears ratios;  
Liquid-cooled. Solution designed for commercial applications with a high number of reversals,  
PTO up to 3000rpm.



## Liquid Cooled

Reduction ratio  $i = 1.40 - 1.88 - 2.25 - 2.75$

Propeller rpm = motor rpm/i

### Including:

- Mounting brackets and silent blocks
- Live PTO available
- Marine gear with integrated thrust bearing (up to 130 kW)
- Oil temperature sensor
- Output offset 103 mm
- Elastic coupling between motor and transmission
- Vector control inverter IP65
- Precharge circuit
- DC-DC converter 12/24 Vdc
- For 48/96/144Vdc systems, 5m cable for display, lever, key
- Quick install / easy connect / plug and play
- Inlet and outlet liquid connections
- Throttle lever (TFC)
- Self priming pump (mechanical) mounted aboard
- Oil-water cooler mounted aboard
- Closed loop liquid cooling mounted aboard
- For 288/384V(307/409V) systems - Electric box (500x500mm) and wiring
- Key panel (OFF-ON-ECO) / For 288/384V(307/409V) key panel (OFF-ON)
- TFEasy display NMEA2000 (only for 45W-65W-100W-130W)



### Optional:

- Main switch and main fuse (Only for 48/96/144Vdc battery w/o internal switch and fuse)
- TFEasy display NMEA2000
- Drop box DP280 (ratio  $i = 1.59 - 2.01 - 2.41 - 2.87 - 3.35 - 3.97 - 5.01$ )



Medium & Heavy Duty

PRODUCT CODE	DESCRIPTION	MOTOR SIZE	NOMINAL hp	INTERMITTENT hp	BATTERY Vdc	MOTOR rpm
BV230025W ...	ShaftMaster 25W	220-20	26	33	96 (102)	3000
BV230035W ...	ShaftMaster 35W	220-20	40	46	144 (140)	
BV230045W ...	ShaftMaster 45W	220-35	46	60	288 (307)	
BV230065W ...	ShaftMaster 65W	300-50	67	87		
BV230100W ...	ShaftMaster 100W	300-75	100	134	384 (409)	
BV230130W ...	ShaftMaster 130W	300-75	134	174		

(...) According to reduction ratio  
( ) Transfluid battery

• Complete the scope of supply with accessories from p. 19

# SternMaster

Permanent magnet motors with steerable and trimmable Stern Drive transmission; available with air or liquid cooling.

## Air Cooled

Reduction ratio  $i = 2$

Propeller rpm = motor rpm/i

### Including:

- Motor with mounting brackets and silent blocks
- Vector control inverter IP65
- Precharge circuit
- DC-DC converter 12 Vdc
- 5m cable for display, lever, key
- Quick install / easy connect / plug and play
- Throttle lever with mechanical actuator (TFC)
- Elastic coupling between motor and transmission
- Trim kit

### Optional:

- Main switch and main fuse (Only for 48/96/144Vdc battery w/o internal switch and fuse)
- TFEasy display NMEA2000



PRODUCT CODE	DESCRIPTION	MOTOR SIZE	Light & Medium Duty		BATTERY Vdc	MOTOR rpm
			NOMINAL hp	INTERMITTENT hp		
BV330020A ...	SternMaster 20A	220-20	20	26	96 (102)	3000
BV330025A ...	SternMaster 25A	220-20	26	33	144 (140)	

(...) According to configuration  
( ) Transfluid battery

## Liquid Cooled

Reduction ratio  $i = 2$

Propeller rpm = motor rpm/i

### Including:

- As above
- Inlet and outlet liquid connections
- ▲ Electric box (500x500mm) and wiring - DC-DC converter 24 Vdc
- Key panel (OFF-ON)

### Optional:

- As above



PRODUCT CODE	DESCRIPTION	MOTOR SIZE	Medium & Heavy Duty		BATTERY Vdc	MOTOR rpm
			NOMINAL hp	INTERMITTENT hp		
BV330025W ...	SternMaster 25W	220-20	26	33	96 (102)	3000
BV330035W ...	SternMaster 35W	220-20	40	46	144 (140)	
BV330045W ...	SternMaster 45W	220-35	46	60	288 (307)	
BV330065W ...	SternMaster 65W	300-50	67	87		
BV330097W ...	SternMaster 97W	300-75	100	130		

(...) According to propeller rotation  
( ) Transfluid battery

• Complete the scope of supply with accessories from p. 19

# DriveMaster 260w

This motor equips DriveMaster - ShaftMaster - SternMaster, operated independently by two inverters.

## Liquid cooled

### Including:

- With foot mountings and silent blocks
- Vector control inverter IP65
- Precharge circuit
- DC-DC converter 24 Vdc
- Electric box (600x600mm) and wiring
- Key panel (OFF-ON)
- Inlet and outlet connections
- Throttle lever TFC

### Optional:

- TFEasy display NMEA2000
- Switching box for redundancy.



Medium & Heavy Duty

PRODUCT CODE	DESCRIPTION	MOTOR SIZE	NOMINAL hp	INTERMITTENT hp	BATTERY Vdc	MOTOR rpm
BV102260W	DriveMaster 260W	375-200	268	348	384 (409)	2300

( ) Transfluid battery

# ShaftMaster 260w

## Liquid cooled

reduction ratio i = 2.06 - 3 - 3.52

### Including:

- With mounting brackets and silent blocks
- Marine gear with integrated thrust bearing
- Inlet and outlet liquid connections
- Throttle lever (TFC)
- Oil temperature sensor
- Oil-water cooler mounted aboard
- Closed loop liquid cooling mounted aboard
- Vector control inverter IP65
- Precharge circuit
- DC-DC converter 24 Vdc
- Elastic coupling between motor and transmission
- Electric box (600x600mm) and wiring
- Key panel (OFF-ON)

### Optional:

- TFEasy display NMEA2000
- Switching box for redundancy.



Medium & Heavy Duty

PRODUCT CODE	DESCRIPTION	MOTOR SIZE	NOMINAL hp	INTERMITTENT hp	BATTERY Vdc	MOTOR rpm
BV230260W ...	ShaftMaster 260W	375-200	268	348	384 (409)	2300

(...) According to reduction ratio  
( ) Transfluid battery

• Complete the scope of supply with accessories from p. 19



## SternMaster 130w

### Liquid cooled

reduction ratio i = apply to Transfluid

#### Including:

- Motor with mounting brackets and silent blocks
- Vector control inverter IP65
- Precharge circuit
- DC-DC converter 24 Vdc
- Elastic coupling between motor and transmission
- Trim kit
- Throttle lever with mechanical actuator (TFC)
- Key panel (OFF-ON)
- Electric box (500X500mm) and wiring
- Inlet and outlet connections

#### Optional:

- TFEasy display NMEA2000



Medium & Heavy Duty

PRODUCT CODE	DESCRIPTION	MOTOR SIZE	NOMINAL hp	INTERMITTENT hp	BATTERY Vdc	MOTOR rpm
BV330130W ...	SternMaster 130W	300-100	134	174	384 (409)	3000

(...) According to configuration

() Transfluid battery

\* Depends on propeller rotation

## SternMaster 260w

### Liquid cooled

reduction ratio i = apply to Transfluid

#### Including:

- Motor with mounting brackets and silent blocks
- Vector control inverter IP65
- Precharge circuit
- DC-DC converter 24 Vdc
- Throttle lever with mechanical actuator (TFC)
- Elastic coupling between motor and transmission
- Trim kit
- Key panel (OFF-ON)
- Electric box (600x600mm) and wiring

#### Optional:

- TFEasy display NMEA2000
- Switching box for redundancy.



Medium & Heavy Duty

PRODUCT CODE	DESCRIPTION	MOTOR SIZE	NOMINAL hp	INTERMITTENT hp	BATTERY Vdc	MOTOR rpm
BV330260W ...	SternMaster 260W	375-200	268	348	384 (409)	2300

(...) According to configuration

() Transfluid battery

\* Depends on propeller rotation

• Complete the scope of supply with accessories from p. 19

# SailMaster

Permanent magnet motors with Sail Drive transmission; available with air or liquid cooling.  
Ideal for sail boats with regeneration via dragged propeller.

## Air Cooled

Reduction ratio  $i = 2$

Propeller rpm = motor rpm/i

### Including:

- Motor with mounting flange
- Vector control inverter IP65
- Precharge circuit
- DC-DC converter 12 Vdc
- 5m cable for display, lever, key
- Quick install / easy connect / plug and play
- key panel (OFF-ON-ECO)

### Optional:

- Main switch and main fuse (Only for 48/96/144Vdc battery w/o internal switch and fuse)
- TFEasy display NMEA2000



PRODUCT CODE	DESCRIPTION	MOTOR SIZE	Light & Medium Duty		BATTERY Vdc	MOTOR rpm
			NOMINAL hp	INTERMITTENT hp		
BV101611A	SailMaster 5A	180-8	5	6	48 (51)	1500
BV101901A	SailMaster 7A	180-12	6	9		
BV101922A	SailMaster 10A	220-20	10	13		
BV101933A	SailMaster 8A	180-12	8	10	96 (102)	1500
BV101955A	SailMaster 12A	180-12	10	16		3000
BV101944A	SailMaster 15A	220-20	13	20		1500
BV101476A	SailMaster 20A	220-20	20	26		3000

( ) Transfluid battery

• Complete the scope of supply with accessories from p. 19

# SailMaster

## Liquid Cooled

Reduction ratio  $i = 2$

Propeller rpm = motor rpm/i

### Including:

- Motor with mounting flange
- Vector control inverter IP65
- Precharge circuit
- DC-DC converter 12 Vdc / For 288V(307V) DC-DC converter 24Vdc
- 5m cable for display, lever, key
- Quick install / easy connect / plug and play
- Inlet and outlet liquid connections
- key panel (OFF-ON-ECO) / For 288V(307V) key panel (OFF-ON)

### Optional:

- Main switch and main fuse (Only for 48/96/144Vdc battery w/o internal switch and fuse)
- TFEasy display NMEA2000
- Regeneration kit (Cable + Key panel ON-OFF)



PRODUCT CODE	DESCRIPTION	MOTOR SIZE	Medium & Heavy Duty		BATTERY Vdc	MOTOR rpm
			NOMINAL hp	INTERMITTENT hp		
BV100882W	SailMaster 7W	180-8	6	9	48 (51)	1500
BV101474W	SailMaster 10W	180-12	10	13		
BV101475W	SailMaster 15W	220-20	13	20		
BV101955W	SailMaster 18W	180-12	16	24	96 (102)	3000
BV101476W	SailMaster 25W	220-20	26	33		
BV530035W	SailMaster 35W	220-20	40	46	144 (140)	
BV530045W	SailMaster 45W	220-35	46	60	288 (307)	

( ) Transfluid battery

• Complete the scope of supply with accessories from p. 19

# SquidMaster

Permanent magnet motors with SailMaster transmission and integrated stern jet thruster up to 45kW (patented); Available with air or liquid cooling.

## Air Cooled

Reduction ratio  $i = 2$

Propeller rpm = motor rpm/i

### Including:

- Motor with mounting flange
- Vector control inverter IP65
- Precharge circuit
- DC-DC converter 12 Vdc
- 5m cable for display, lever, key
- Quick install / easy connect / plug and play
- TFEasy display NMEA2000
- key panel (OFF-ON-ECO)

### Optional:

- Main switch and main fuse (Only for 48/96/144Vdc battery w/o internal switch and fuse)



### Light & Medium Duty

PRODUCT CODE	DESCRIPTION	MOTOR SIZE	NOMINAL hp	INTERMITTENT hp	BATTERY Vdc	MOTOR rpm	THRUST ft/lbs
BV430020A	SquidMaster 20A	220-20	20	26	96 (102)	3000	504.8

( ) Transfluid battery

## Liquid Cooled

Reduction ratio  $i = 2$

Propeller rpm = motor rpm/i

### Including:

- As above
- For 288V(307V) DC-DC converter 24Vdc
- For 288V(307V) key panel (OFF-ON)

### Optional:

- As above

### Medium & Heavy Duty

PRODUCT CODE	DESCRIPTION	MOTOR SIZE	NOMINAL hp	INTERMITTENT hp	BATTERY Vdc	MOTOR rpm	THRUST ft/lbs
BV430025W	SquidMaster 25W	220-20	26	33	96 (102)	3000	506.2
BV430035W	SquidMaster 35W	220-20	40	46	144 (140)		506.2
BV430045W	SquidMaster 45W	220-35	46	60	288 (307)		650.9

( ) Transfluid battery

• Complete the scope of supply with accessories from p. 19



# SquidMaster

## With Stern JET



Joystick



Lever

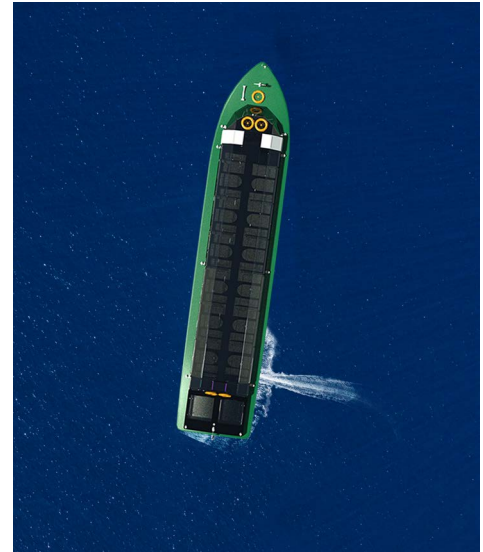

## With Combi JET

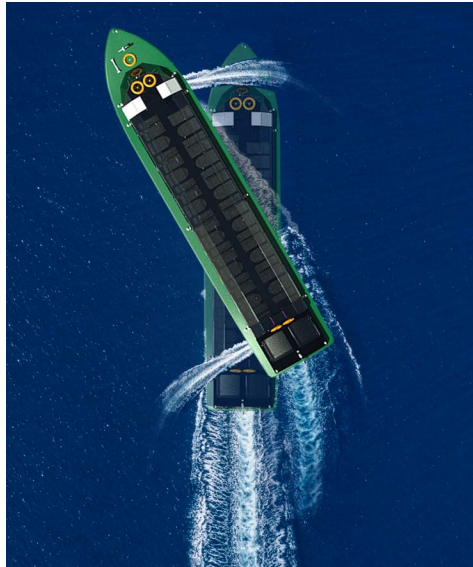
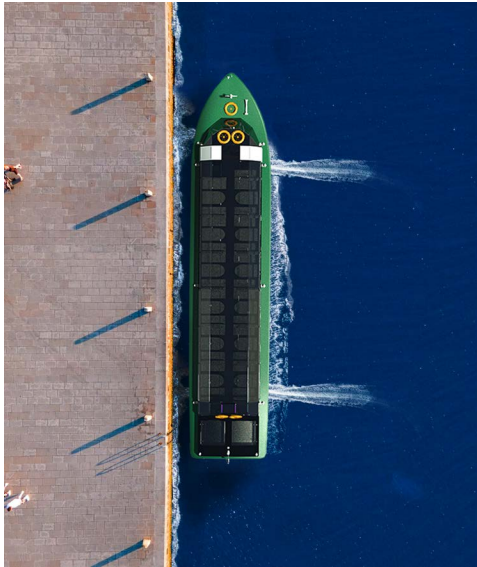

SQUID Joystick-lever

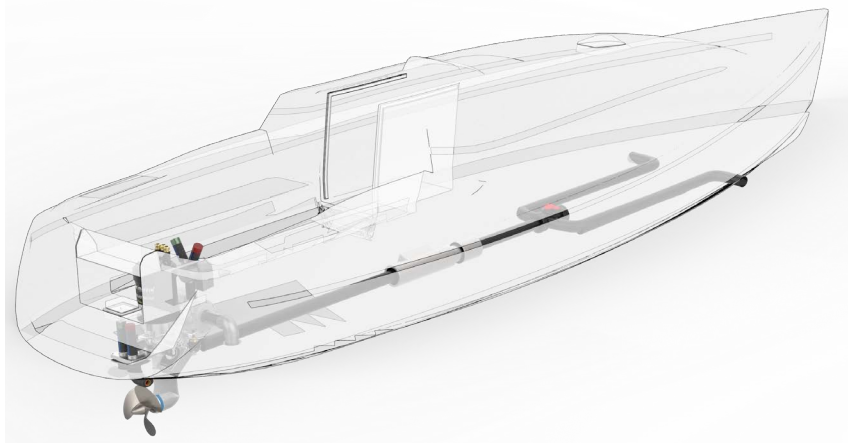

# OutboardMaster

Permanent magnet motors in the Outboard version; available with air or liquid cooling.  
Long-lasting outboard designed for work boats or for frequent use.

## Air Cooled

Reduction ratio  $i=2$

Propeller rpm = motor rpm/i

### Including:

- Motor with mounting brackets
- Vector control inverter IP65
- Anti ventilation / cavitation plate (incl. anode)
- Precharge circuit
- DC-DC converter 12 Vdc
- 5m cable for display, lever, key
- Quick install / easy connect / plug and play
- Key panel (OFF-ON-ECO)

### Optional:

- Main switch and main fuse (Only for 48/96/144Vdc battery w/o internal switch and fuse)
- TFEasy display NMEA2000



(Propeller not included)

### Light & Medium Duty

PRODUCT CODE	DESCRIPTION	MOTOR SIZE	NOMINAL hp	INTERMITTENT hp	BATTERY Vdc	MOTOR rpm
BV630005A	OutboardMaster 5A	180-8	5	6	48 (51)	1500
BV101966A	OutboardMaster 7A	180-12	6	9		
BV101978A	OutboardMaster 10A	220-20	10	13		
BV101977A	OutboardMaster 8A	180-12	8	10	96 (102)	3000
BV101500A	OutboardMaster 12A	180-12	10	16		
BV101988A	OutboardMaster 15A	220-20	13	20		
BV101999A	OutboardMaster 20A	220-20	20	26		

( ) Transfluid battery

## Liquid Cooled

Reduction ratio  $i=2$

Propeller rpm = motor rpm/i

### Including:

- As above
- Inlet and outlet liquid connections
- For 288V(307V) DC-DC converter 24Vdc
- For 288V(307V) key panel (OFF-ON)

### Optional:

- As above

### Medium & Heavy Duty

PRODUCT CODE	DESCRIPTION	MOTOR SIZE	NOMINAL hp	INTERMITTENT hp	BATTERY Vdc	MOTOR rpm
BV101966W	OutboardMaster 10W	180-12	10	13	48 (51)	1500
BV101977W	OutboardMaster 15W	220-20	13	20		
BV101500W	OutboardMaster 18W	180-12	16	24	96 (102)	3000
BV101988W	OutboardMaster 25W	220-20	26	33		
BV630035W	OutboardMaster 35W	220-20	40	46		
BV630045W	OutboardMaster 45W	220-35	46	60	288 (307)	

( ) Transfluid battery

• Complete the scope of supply with accessories from p. 19

# Accessories

## Bellcontrol Throttle

- Water resistant (IP67)
- Electronic hall-sensor technology 0-5 Volt.
- With adapter cable

### Top mounting single

P. CODE	DESCRIPTION	TYPE	TOP MOUNT
BVTE3284AE	Bellstyle	TC1-15	Stainless Steel version with black delrin base, top mount, IP67 (contactless hall effect sensor, 0-5V output)



TC1-15

### Side mounting

P. CODE	DESCRIPTION	TYPE	SIDE MOUNT
BVTE3284AF	Bellstyle	S15	Stainless Steel version, side mount, IP67 (contactless hall effect sensor, 0-5V output)



S15

### Top mounting dual

P. CODE	DESCRIPTION	TYPE	TOP MOUNT - DUAL CONTROL
BVTE3284BC	Bellstyle	TC2-15	Stainless Steel version with black delrin base, dual joystick top mount, IP67 (contactless hall effect sensor, 2x 0-5V output)



TC2-15

## TFcontrol Throttle

- Water resistant (IP67)
- With adapter cable
- Second control station available upon request
- Mandatory for 288V (307V) and 384V (409V) systems

PRODUCT CODE	DESCRIPTION	TYPE	TOP MOUNT
BVTE3274..A	Single station for single screw	TFC1-11	Stainless handle, top mount, IP67 (0-5V output)
BVTE3274..B	Single station for twin screw	TFC2-11	Stainless handle, top mount, IP67 (0-5V output)



TFC1-11



TFC2-11

Pay attention: Engine room must be ventilated

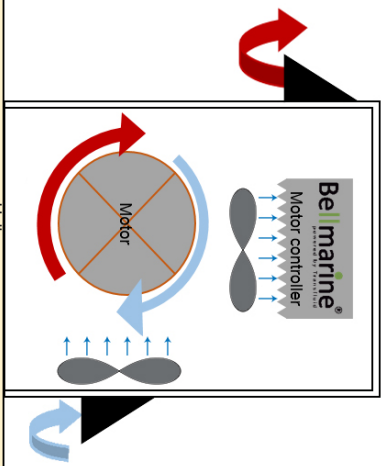

### Air-cooling:

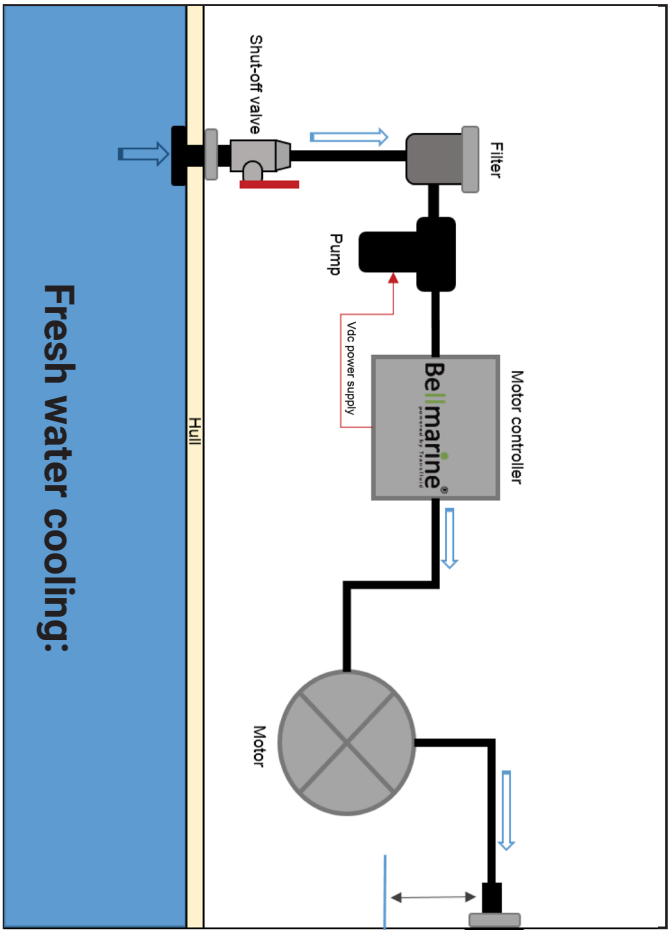

### Fresh water cooling:

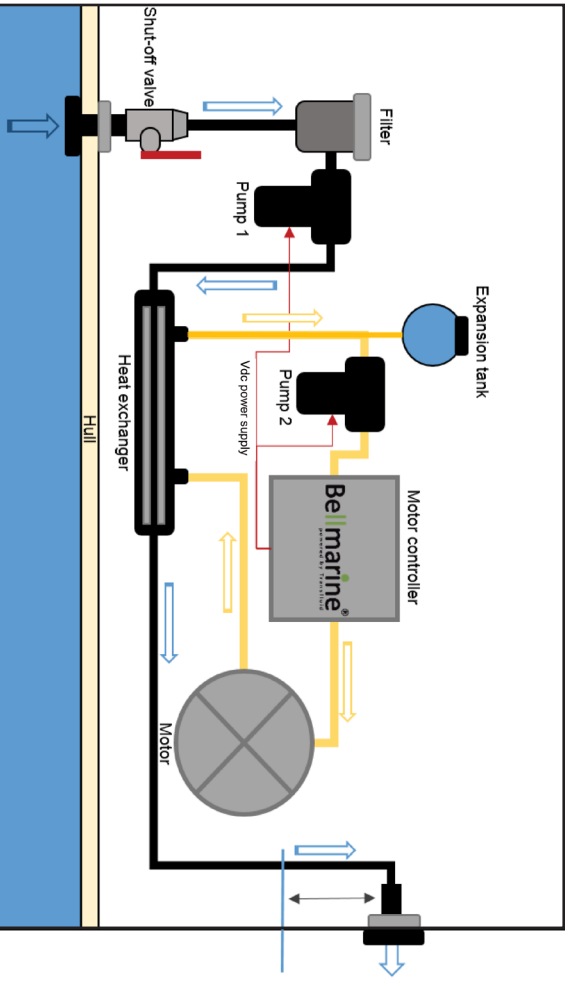

### Closed loop liquid cooling:

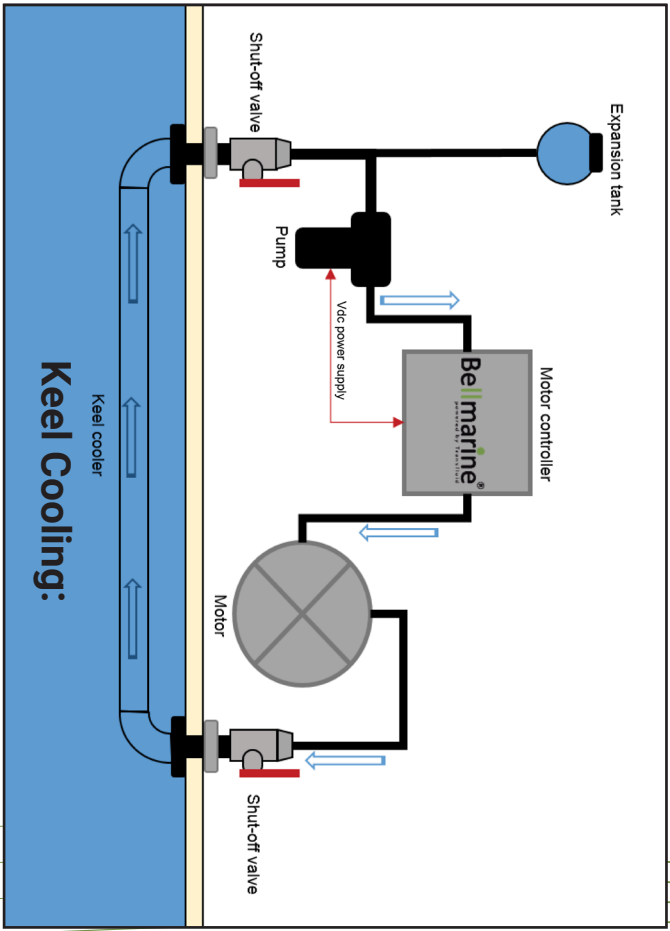

### Keel Cooling:

# Accessories

## Liquid Cooling

### Fresh water cooling

PRODUCT CODE		DESCRIPTION	
100798A	12V	Cooling System with install connections kit	Includes: self priming pump, 2 x hull fittings, ball valve, bronze water strainer, 5 m hose, hose barbs and SS hose clamps.
100798B	24V		



### Closed loop cooling

PRODUCT CODE		DESCRIPTION	SIZE	POWER ADVISE
101446	12V	Cooling System with install connections kit	S	Up to 26 hp
101447	12V		M	26 to 73 hp
101447A	24V		L	73> hp
101448A	24V			

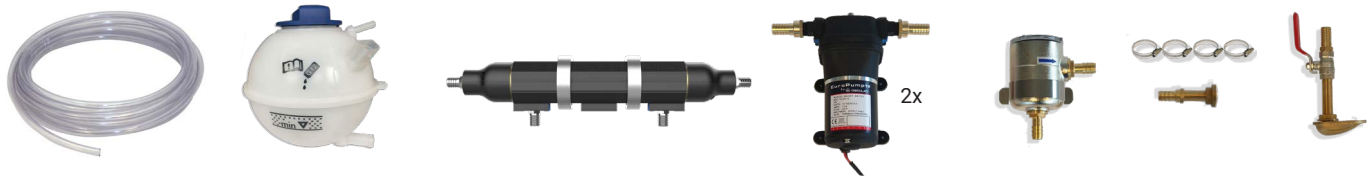

### Keel cooling

PRODUCT CODE		DESCRIPTION	
101531A	12V	Cooling System with install connections kit	Includes: Circulation pump, 5 m hose, expansion vessel, 2x hull fittings, 2x ball valves, and SS brackets, hose barbs and SS hose clamps.
101531B	24V		



# Accessories

## Propeller shaft assembly

### Motor - Propeller Shaft Couplings

PRODUCT CODE	DESCRIPTION	
101219A ...	Motor - shaft clamping <b>Ø 25 mm bore</b>	To be used in combination with propeller shaft Ø 25 mm. (produced in Stainless Steel) - Up to 180-12 motor size.
101220A ...	Motor - shaft clamping <b>Ø 30 mm bore</b>	To be used in combination with propeller shaft Ø 30 mm. (produced in Stainless Steel) - Up to 220-20 and EVO motor size.
GAB3M20 ...	Motor - shaft <b>B3M20 coupling</b>	To be used in combination with propeller shaft Ø 35 mm or Ø 40 mm with rubber blocks (needs separate thrust bearing)

(...) According to machined bores



### Ecoline 25 propeller shaft system (without bracket - without propeller)

PRODUCT CODE	Ø DIA mm	TORQUE ft/lbs	LENGTH mm	STERNTUBE
BV100427	25	36	1500	SS316

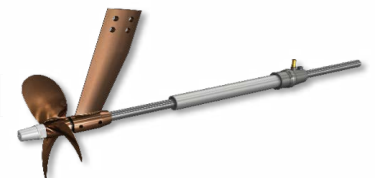

## Optional kits

PRODUCT CODE	DESCRIPTION
BVTF7150AB	<b>Regeneration / during sailing</b> Includes custom cable set and Motor Controller setup
BVTF7150AD	<b>USB / Inverter interface (48/96/144 Vdc) to diagnose or set up your Bellmarine system on distance</b> Includes cables, software and user license
GATF6338BC	USB / Inverter interface (288/384 Vdc)
GMTE3318AA	GPS (Only for TFEasy display)
BVTE3203LA	Emergency cut-off switch



GPS



Emergency cut-off switch

## Shore power cable 230V 16A - 400V 32A



PRODUCT CODE	DESCRIPTION
BVTE3329AA	Set with: 15m cable (3G4mm <sup>2</sup> ), 16A 230V
BVTE3329AB	Set with: 25m cable (3G4mm <sup>2</sup> ), 16A 230V
BVTE3329BA	Set with: 20m cable (5G6mm <sup>2</sup> ), 32A 400V

# Accessories

## Display

For every system a display and cable set is highly recommended for monitoring and control.

- With adapter cable



TF Easy



TF Pro



TF2



PRODUCT CODE	DESCRIPTION	
BVTE3281C	TF Easy	Display with battery status indication (only for TF batteries), motor power, motor rpm, motor temperature, controller temperature, eco meter, battery amps, battery voltage and mode selection. For any type of battery. Incl. cable set for monitoring and control. NMEA2000 communication protocol
BVTE3281G	TF Pro	7"Color display with battery status indication (only for TF batteries), motor power, motor rpm, motor temperature, controller temperature, eco meter, battery amps, battery voltage and mode selection. For any type of battery. Incl. cable set for monitoring and control.
BVTE3281H	TF2	9"Color display with battery status indication (only for TF batteries), motor power, motor rpm, motor temperature, controller temperature, eco meter, battery amps, battery voltage and mode selection. For any type of battery. Incl. cable set for monitoring and control.
BVTE3316A	Extension cable length 2.5m	Signal cable between dashboard and engine room Only for 48/96/144 Vdc (51/102/140 Vdc)
BVTE3316B	Extension cable length 5m	
BVTE3316C	Extension cable length 10m	
BVTE3316D	Extension cable length 15m	
BVTE3280E	Extension cable length 20m	



Motor controller

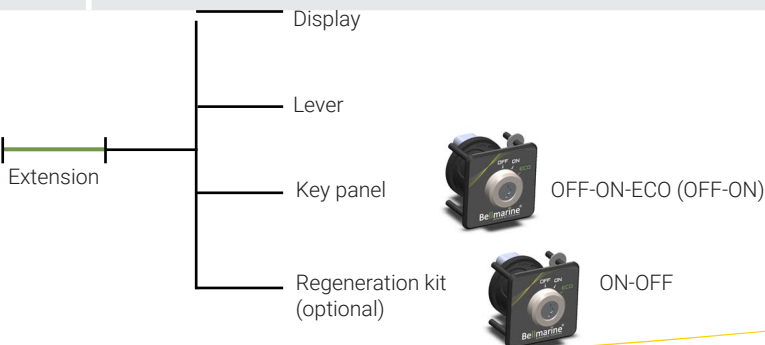

\* Image refers to 48/96/144 Vdc systems

# Accessories

## Battery LiFePO4

Based on Lithium Iron phosphate cells (LiFePO4), a technology that is safe and has the best performance/cost ratio, with integrated BMS to maintain the cells always equalized and efficient. Box is stainless steel IP65.

### Long lifespan

- More than 4,000 cycles

The lifespan is 3 times longer than traditional batteries, making the cost per cycle lower. Maintenance-free, planned service is avoided, having no need of topping up or periodical checks. The conditions of the battery can be easily verified thanks to integrated diagnosis systems. No gas emissions during charge and discharge, so no special charging rooms are required. They may be charged at any place with maximum safety.

### Suited for every application

Having no gas emissions, these batteries are suited also for marine and many industrial applications.

**Apply Transfluid-Bellmarine for CAN-bus wires kit; 2m, 5m, 10m, 15m, 20m. (for battery and battery charger)**

Capacity Ah	Contin. discharge A	Pulse discharger A	Max charging current A	Pulse charge A	Operating Temperature °F	Box Material	Protection class
105	105	210	70	120	14 / 113	SS316L	IP65 (No cooling required)
210	210	420	160	240			
315	315	630	210	360			
420	420	840	320	480			
630	630	1260	480	720			
840	840	1680	640	960			

### 51V

Energy kWh	Architecture	Dimension Single Box	Number Of Modules	Total Weight
10.7	Single Module	605x630 h281 mm	1	112 kg
21.5	2P		2 + MCR*	224 kg
32.3	3P		3 + MCR*	336 kg
43.0	4P		4 + MCR*	448 kg



### 102V

Energy kWh	Architecture	Dimension Single Box	Number Of Modules	Total Weight
10.7	Single Element	605x630 h281 mm	1	112 kg
21.5	Single Element	955x630 h281 mm	1	187 kg
32.2	3P	605x630 h281 mm	3 + MCR*	336 kg
43.0	2P	955x630 h281 mm	2 + MCR*	374 kg
64.5	3P		3 + MCR*	561 kg
86.0	4P		4 + MCR*	748 kg

### 140V

Energy kWh	Architecture	Dimension Single Box	Number Of Modules	Total Weight
29.5	3S	605x630 h281 mm	3	336 kg
59.1	3S - 2P		6 + MCR*	672 kg
88.7	3S - 3P		9 + MCR*	1008 kg
118.2	3S - 4P		12 + MCR*	1344 kg

### 48V Easy (without Type Approval)

Energy kWh	Architecture	Dimension Single Box	Number Of Modules	Total Weight
10.7	Single Module	420x750 h275 mm	1	101 kg

# Accessories

## 307V

Energy kWh	Architecture	Dimension Single Box	Number Of Modules	Total Weight
32.2	3S	605x630 h281 mm	3	336 kg
64.5	3S	955x630 h281 mm	3	561 kg
96.7	3S - 3P	605x630 h281 mm	9 + MCR*	1008kg
129.0	3S - 2P	955x630 h281 mm	6 + MCR*	1122 kg
193.5	3S - 3P		9 + MCR*	1683 kg
258.0	3S - 4P		12 + MCR*	2244kg

## 409V

Energy kWh	Architecture	Dimension Single Box	Number Of Modules	Total Weight
43	4S	605x630 h281 mm	4	448 kg
86	4S	955x630 h281 mm	4	748 kg
129	4S - 3P	605x630 h281 mm	12 + MCR*	1344 kg
172	4S - 2P	955x630 h281 mm	8 + MCR*	1496 kg
258	4S - 3P		12 + MCR*	2244 kg
344	4S - 4P		16 + MCR*	2992 kg



\* MCR dimensions: 400x350xh167 mm, weight: 11 kg

\* Collector box included. Ask for official drawing

## TF LiFePO4 battery charger

- Battery state of charge readable from display (only TFEasy display and TF battery)
- Air cooled



PRODUCT CODE	TYPE	BATTERY VOLTAGE Vdc	CHARGE CURRENT Adc	INPUT VOLTAGE Vac
GMTE3239AA	DC230 48 3K	51	40	230
GMTE3239AB	DC400 48 7K	51	100	3 x 400
GMTE3239BA	DC230 96 3K	102	22	230
GMTE3239BB	DC400 96 7K	102	65	3 x 400
GMTE3239CA	DC230 144 3K	140	20	230
GMTE3239CB	DC400 144 9K	140	55	3 x 400
GMTE3239DA	DC400 288 9K	307	25	3 x 400
GMTE3239EA	HV11K AC	307 - 409	33-25	230 3 x 400
GMTE3239EA2	HV22K AC		66-50	
GMTE3239EA3	HV33K AC		99-75	
GMTE3312AA	DC230 48 3K - easy	48V Easy	40	230
GMTE3312AB	DC400 48 7K - easy	48V Easy	100	3 x 400

- More Models Available upon Request (also 115Vac input)

# Accessories

## DC/AC Inverter

Pure sinewave output provides the ideal power source for modern electronics. Short-circuit proof robust design that protects itself against AC shorts. Sophisticated circuitry provides protection against overload, short circuit and over temperature. The benefits include:

- Inverter protection to withstand high vibration and movement.

A must-have for all mobile and marine applications.

- Allows the inverter to be connected to a secondary power source (eg. Generator, Grid).
- Peak efficiency 97 %.
- Power factor 0.8

PRODUCT CODE	TYPE	BATTERY VOLTAGE V	POWER kw	OUTPUT VOLTAGE Vac
GMTE3388AA	LV inverter kit	48 Easy - 51	2	230
GMTE3388BA		102		
GMTE3388CA		140		
GMTE3282B...	HV inverter kit	307 - 409	10	3x400
GMTE3282D...			21	
GMTE3282C...			43	
GMTE3282A...			85	

## DC-DC converter

- Isolated switching regulator:
- Encapsulated IP65
- Vibration resistant
- Short circuit and overtemperature protection
- Compact design
- On / Off Key switch input
- Wide input range



PRODUCT CODE	TYPE	BATTERY VOLTAGE V	OUTPUT VOLTAGE V	POWER W
LOW VOLTAGE (LV)				
NE2170AU	DC4812450	48 Easy 51	12	450
NE2170AX	DC4824450		24	
NE2170AV	DC9612450	102	12	
NE2170AW	DC9624450		24	
NE2170AY	DC14412450	140	12	
NE2170AZ	DC14424450		24	
HIGH VOLTAGE (HV)				
GMTE3277AA	DVCH-1503-400-12	307 - 409	12	1500
GMTE3277AB	DVCH-1503-400-24		24	
GMTE3277AC	DVCH-3003-400-12		12	3000
GMTE3277AD	DVCH-3003-400-24		24	



See also Transfluid Hybrid & Electric Technology catalog

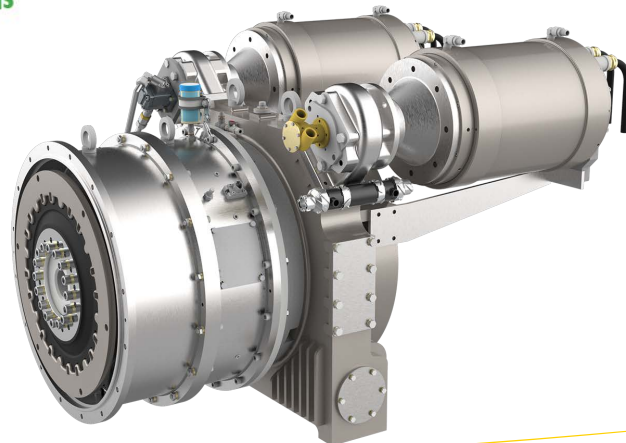
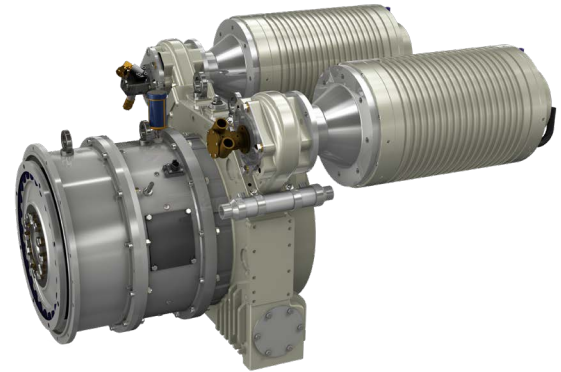
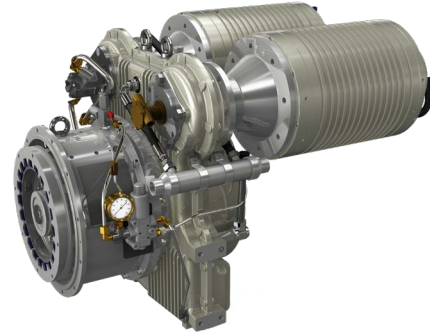
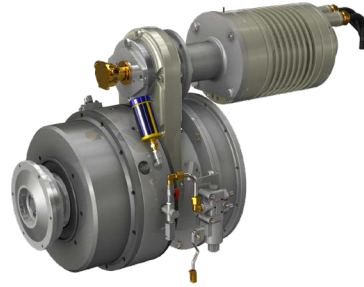

**TRANSFLUID**  
Industrial & marine

**HYBRID & ELECTRIC  
TECHNOLOGY**

drive with us

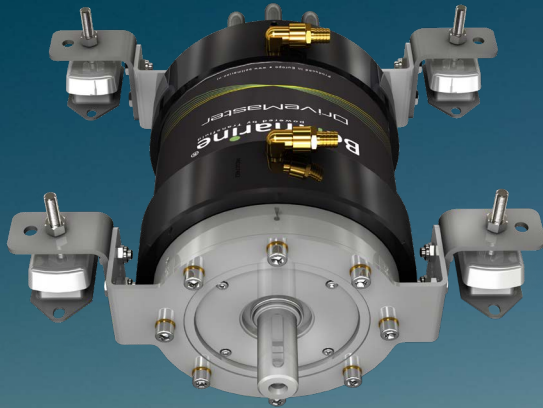

Electric boating starts at Bellmarine

**TRANSFLUID<sup>®</sup>**  
**industrial & marine**

**U.S.A.**

TRANSFLUID LLC  
Auburn, GA 30011  
Ph. +1.770.822.1777  
salesna@transfluid.us

**ITALY**

TRANSFLUID S.p.A.  
Via Guido Rossa, 4  
21013 Gallarate (VA)  
Ph. +39.0331.28421  
info@transfluid.eu

**THE NETHERLANDS**

TRANSFLUID NORTH EUROPE B.V.  
**Bellmarine**  
NL- 3992 AK, Houten  
Ph. +31 (0)85 4868530  
info@bellmarine.nl

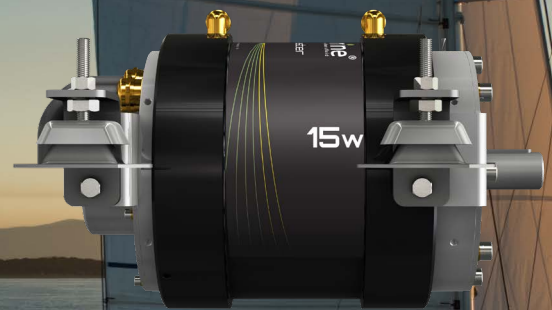

AUGUST 2025