



**TRANSFLUID**  
Industrial & marine

# HB - HYBRID BOOSTER



**drive with us**

# Modules

## The System

The hybrid booster works in two specific modes:

- **“Booster” function** that allows the electric motor to assist the engine in providing extra torque to the driveline during acceleration
- **“Regeneration” function** when the electric motor is not required for propulsion, powering the batteries and generating useful energy for onboard services



SAE4  
10

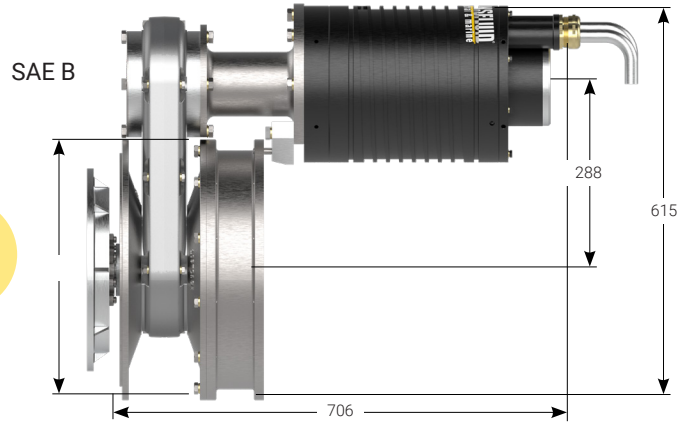

SAE3  
11½

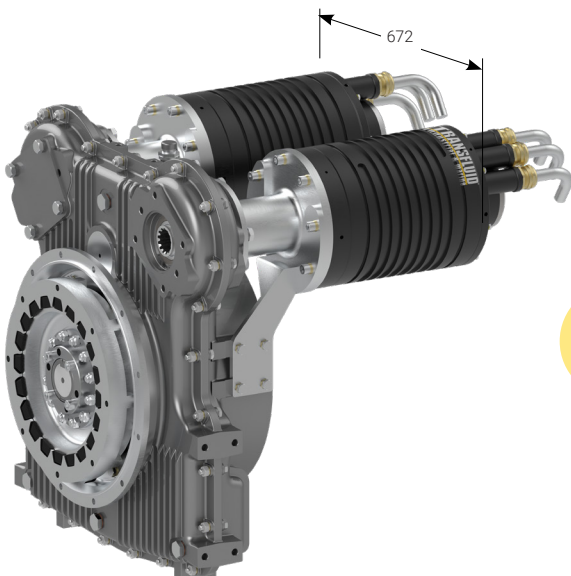
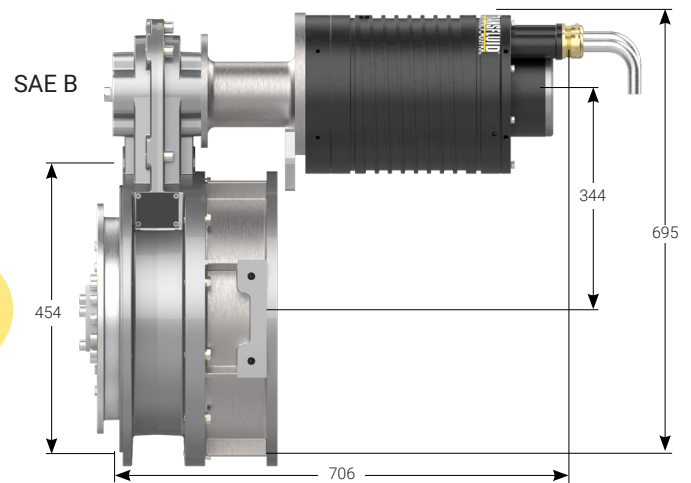

SAE3  
11½

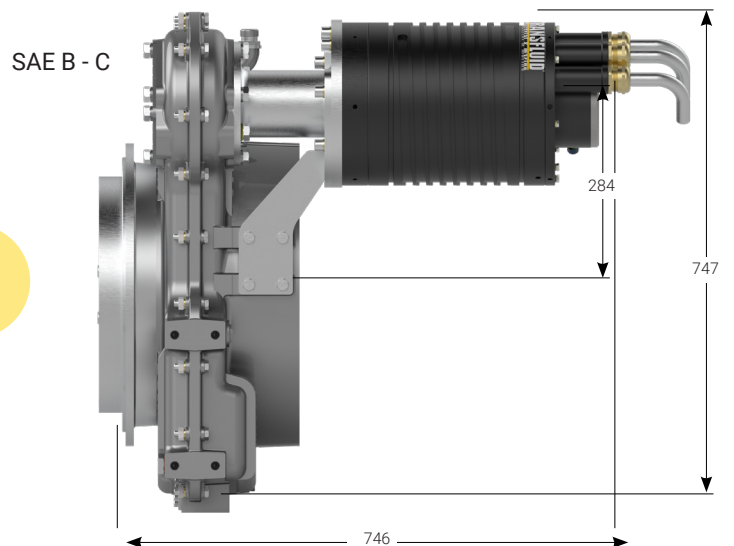

# MC 48-96-144

## Air Cooled

# Scope of Supply

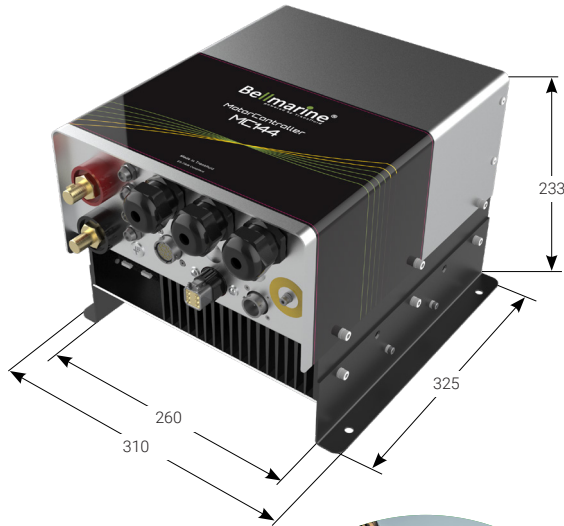

\* MC Air cooled weight: 16 kg (35lb)

\* Collector box included. Ask for official drawing



## How It Works

In the pursuit of increasingly eco-friendly solutions, Transfluid has developed the HB Hybrid Booster, an advanced product that effectively meets the demands of the internal combustion engine market, which is subject to stringent global regulations. These regulations impose power limits that necessitate the adoption of advanced systems for emission reduction.

The HB Hybrid Booster enables the downsizing of internal combustion engines and the limitation of their power output.

The additional power required to achieve the desired performance is provided by the integrated electric motor, ensuring significant emission reductions and increased energy efficiency.

The HB Hybrid Booster also offers the advantage of functioning as a generator when the electric motor is not required for propulsion, powering the batteries and generating useful energy for onboard services. This system ensures optimal operational efficiency and superior sustainability, addressing the challenges of today's market with innovative and environmentally friendly solutions.

MODEL	MAX INPUT TORQUE Nm (lb-ft)	MAX INPUT SPEED rpm	E. MOTOR PEAK POWER kW (hp) - 3000 rpm	INPUT / OUTPUT	EL. CPLG	WEIGHT kg (lb)	BATTERY V
HB 11-25	430 (320)	3000	25 (33)	SAE 4-10"	RBD 10SS	118 (260)	96 (102)
HB 12-35	660 (490)		35 (47)	SAE3 - 11½"	RBD 11S	141 (311)	144 (140)
HB 14-70	1550 (1150)		70 (94)	SAE3 - 11½"	RBD 11D	331 (730)	
HB 11-20 EVO	430 (320)	1500	20 (26) 1500 rpm	SAE4 - 10"	RBD 10SS	118 (260)	48 (51)

\* Available different Transmission - E. motor - SAE combinations  
 • All data can be changed without notice



# TRANSFLUID<sup>®</sup>

## industrial & marine

### ITALY - HEADQUARTERS

TRANSFLUID S.p.A.  
Via Guido Rossa, 4  
21013 Gallarate (VA)  
Ph. +39.0331.28421  
info@transfluid.eu

### U.S.A.

TRANSFLUID LLC  
Auburn, GA 30011  
Ph. +1.770.822.1777  
salesna@transfluid.us

### THE NETHERLANDS

BELLMARINE  
NL- 3992 AK, Houten  
Ph. +31 (0)85 4868530  
info@bellmarine.nl

[www.transfluid.us](http://www.transfluid.us)



# drive with us

September 2024