



2024



TRANSFLUID
industrial & marine

HYBRID & ELECTRIC TECHNOLOGY



drive with us

Transfluid's Hybrid

The industrial market has been focused on developing new technologies to reduce their ecological impact on land and sea.

Global awareness of air, noise and water pollution attributed to internal combustion engines has caused vehicle manufacturers to invest large amounts of money and resources into developing hybrid systems used in automobiles and small commercial vehicles.

However, because of the wide variety of driveline designs used in industrial and marine markets, a standardized, quality, heavy duty "hybrid product" has been impractical to develop.

Accepting the challenge to provide a hybrid product for this neglected market, Transfluid is ready to introduce a solution for low to medium power marine and industrial applications.

For decades, Transfluid has been manufacturing a wide range of power transmission equipments and electric motors/generators.

Profiting from their experience in thousands of industrial and marine applications and using their existing technology, it resulted in the development of the technology of the future.



The System

The hybrid system works in three specific modes:

- **electric propulsion** to drive or sail at ZERO emissions and in absolute silence
- **engine propulsion** that uses the electric machine as a generator to recharge the batteries
- **"booster" function** that allows the electric motor, during acceleration, to assist the engine in providing extra torque to the driveline

How It Works

The input side is a hydraulic or pneumatic controlled clutch.

When disengaged, the engine is disconnected from the rest of the driveline allowing the vehicle or vessel to be operated by the electric motor instead of the engine.

During engine operation, the clutch is engaged and the electric motor becomes a generator, recharging the batteries, if required.

By operating the engine and electric motor at the same time, the "booster" operation is engaged, increasing the total available power to the driven machine.

All operations are controlled via Transfluid's proprietary electronic controller MPCB-R5, which communicates with all equipment through CAN BUS protocol, making the system a simple "plug and play" solution.

Hybrid Transmissions HM



Batteries



Electric Motors



Motor Controllers



Work In Progress

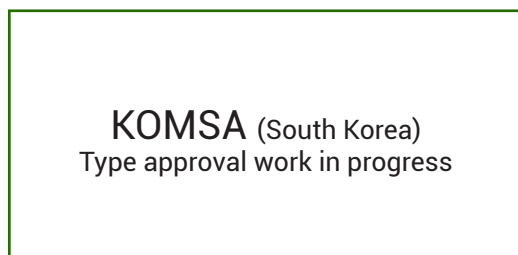

Industrial Hybrid

HM560 with Hydrostatic Transmission

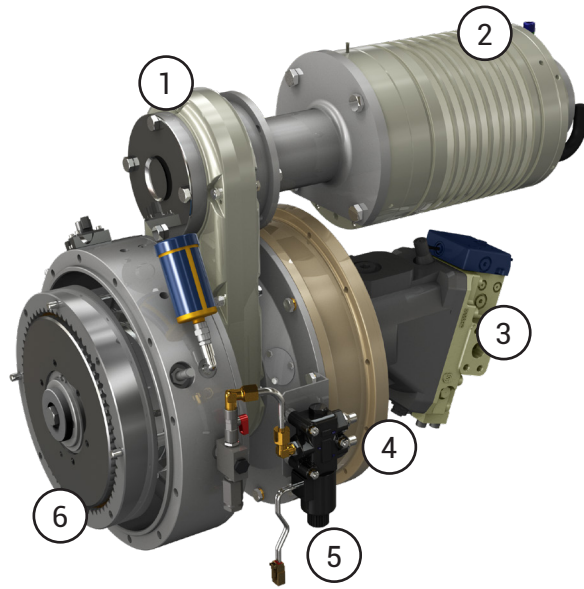

1. Split power drive drive with SAE B PTO
2. Electric machine that can operate as electric motor or electric generator
3. Hydraulic Pump
4. Single Pump drive
5. Clutch actuation solenoid valve
6. SAE standard dry clutch, operated by solenoid valve, to connect and disconnect internal combustion engine

HTV700

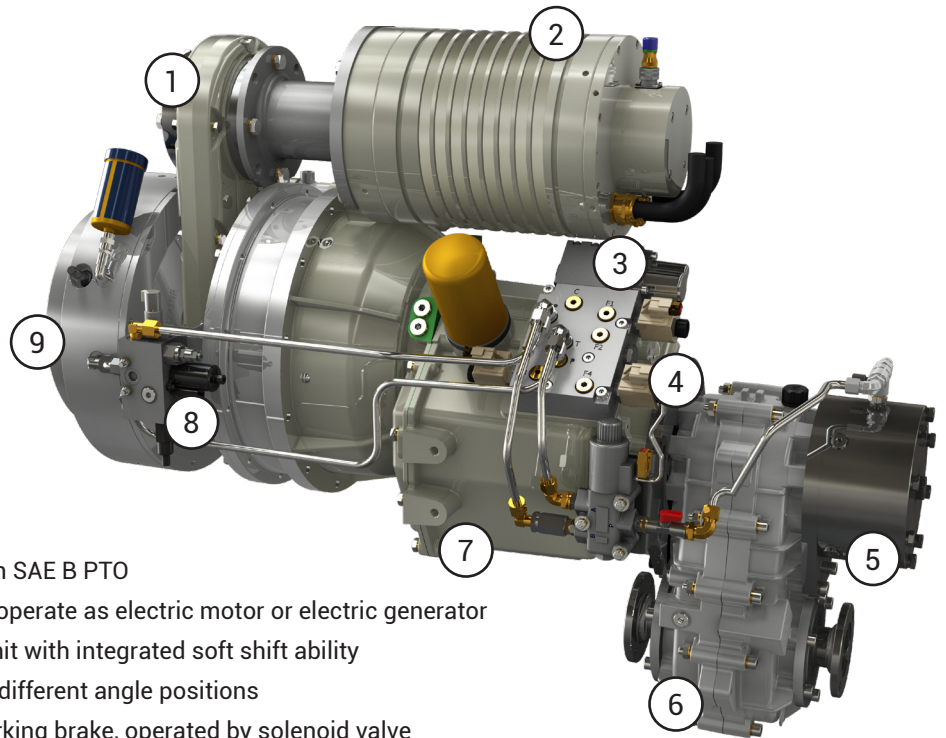

1. Split power drive drive with SAE B PTO
2. Electric machine that can operate as electric motor or electric generator
3. Electric selector control unit with integrated soft shift ability
4. Drop box installation with different angle positions
5. Spring loaded wet disc parking brake, operated by solenoid valve
6. Drop box for 2 or 4 wheel drive, available with wide variety of reduction ratios
7. Three speed forward, one speed reverse Powershift Transmission
8. Clutch actuation solenoid valve
9. SAE standard dry clutch, operated by solenoid valve, to connect and disconnect internal combustion engine

Working Scheme



LEGEND	
—	POWER WIRE
—	CAN WIRE
—	DIGITAL WIRE

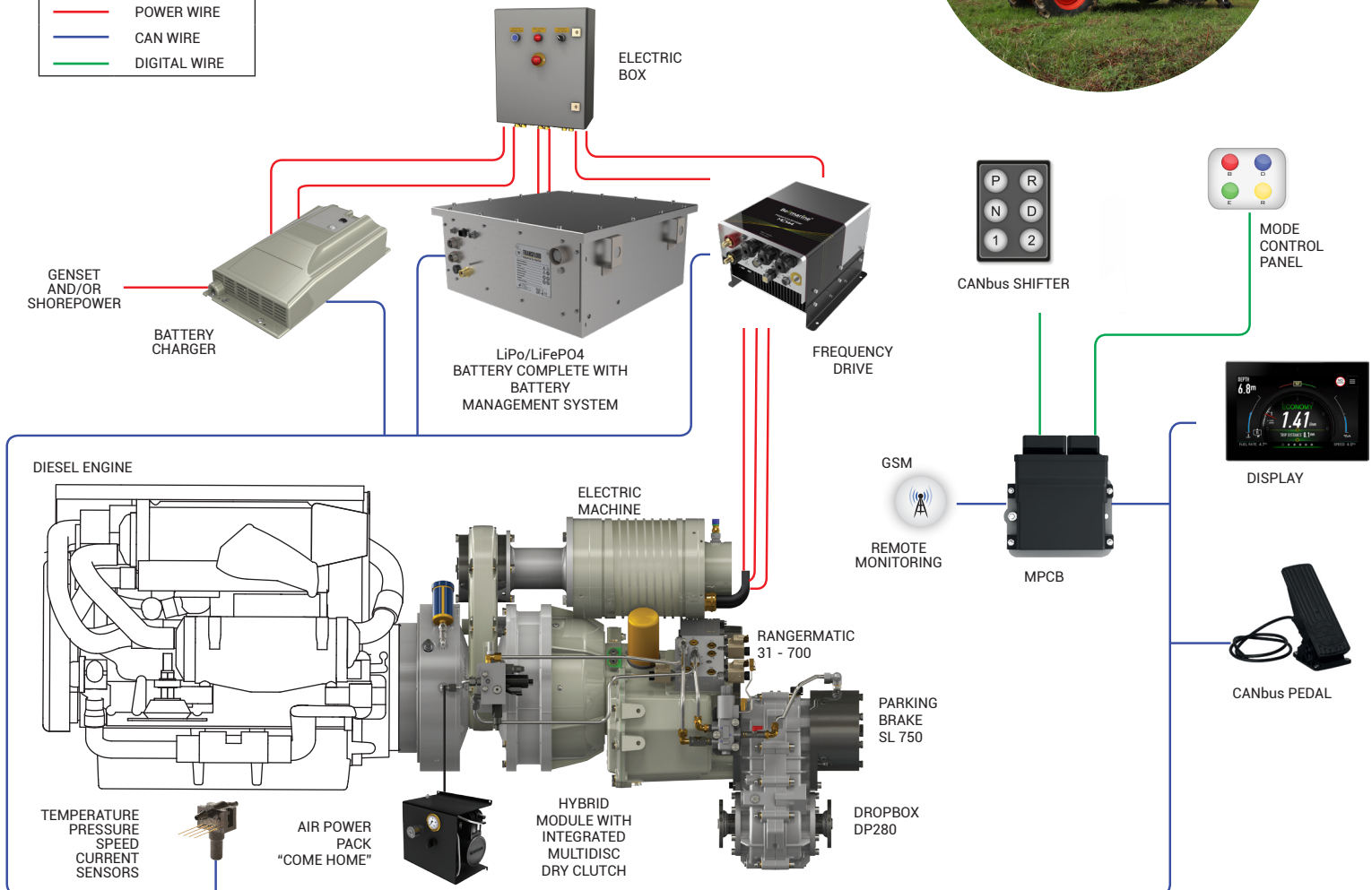

Marine Hybrid

HM560 with Cardan Shaft

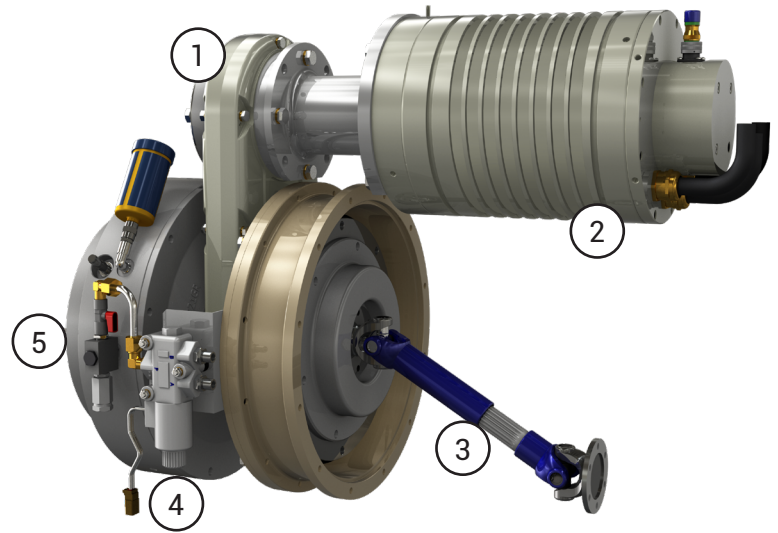

1. Split power drive with SAE B PTO
2. Electric machine that can operate as electric motor or electric generator
3. Cardan shaft
4. Clutch actuation solenoid valve
5. SAE standard dry Clutch, operated by solenoid valve, to connect and disconnect internal combustion engine

HTM700

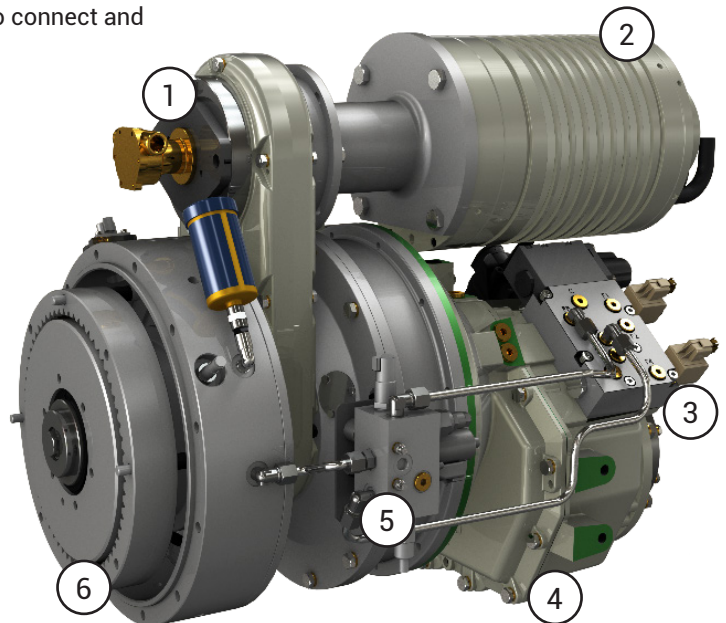

1. Split power drive with SAE B PTO
2. Electric machine that can operate as electric motor or electric generator
3. Electric selector with integrated Soft-Shift ability
4. Forward-Reverse Powershift marine gear
5. Clutch actuation solenoid valve
6. SAE standard dry Clutch, operated by solenoid valve, to connect and disconnect internal combustion engine

Working Scheme



LEGEND	
—	POWER WIRE
—	CAN WIRE

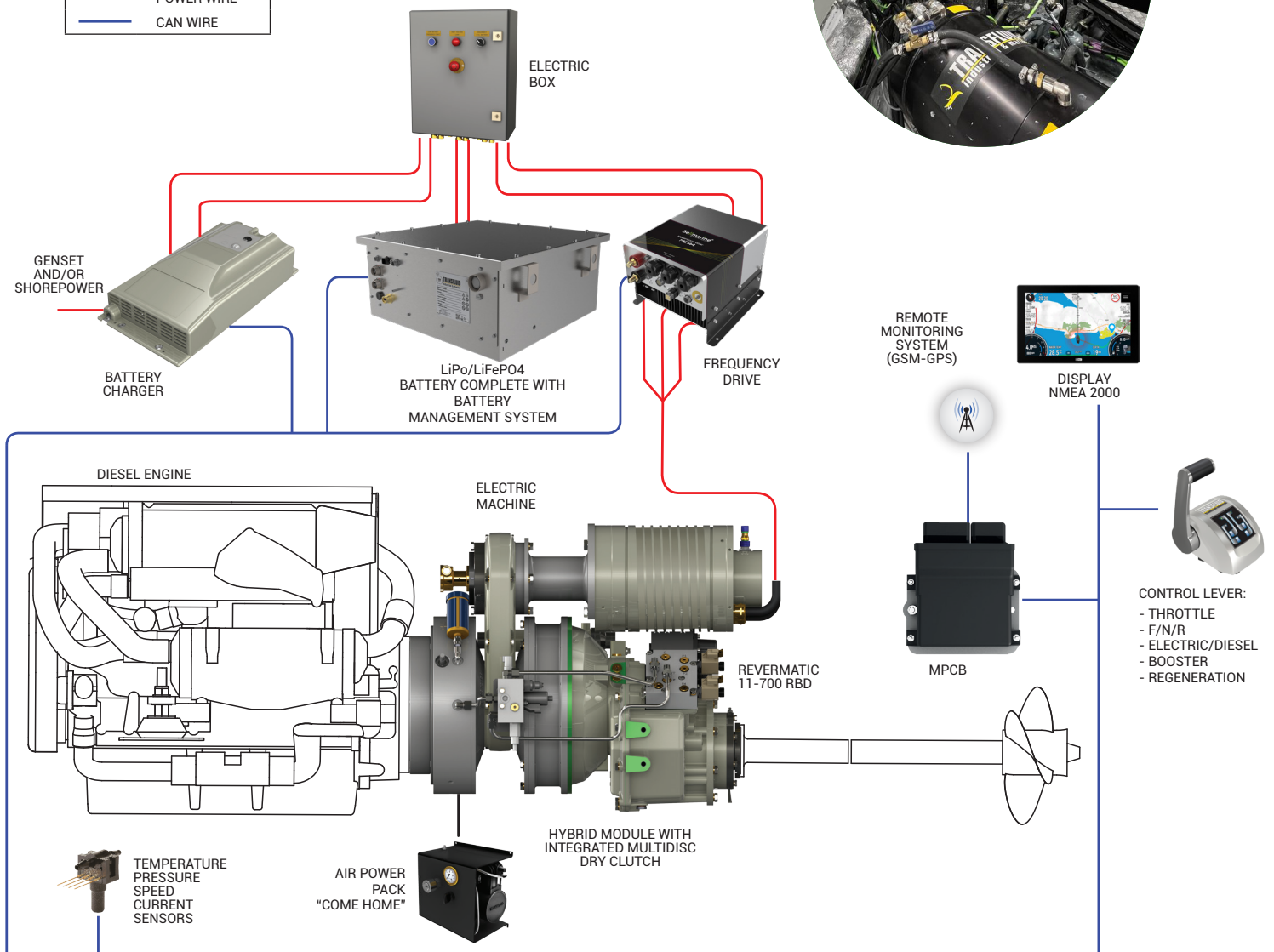

The Hybrid Series: Technical Specifications

In close cooperation with leading battery and motor controller manufacturers, the HM Module series (450-560-2000-3350-6300) was developed to provide a standard, simple, quality solution. Designed to "sandwich" between an engine with a SAE flywheel and housing and transmission with a SAE input, the HM module provides a seamless solution that is easier to apply and simpler to operate than any application specific solution. Additionally, the electric machine (the motor generator) can be mounted in multiple positions in order to provide the best fit for the engine compartment. To install, all that is required is a short distance between the engine and transmission, this make it an ideal solution for retrofits and new designs.

Transfluid also provides two packages that couple the HM technology with their power shift transmissions and marine products. The HTV700 is a complete vehicle transmission product utilizing a power shift transmission, 4WD drop box and brake. Designed to be exceptionally compact, it is ideal for ground support equipment, small mining and construction machines. The HTM700 is a hybrid marine transmission. The electric function is becoming mandatory in many ports where they are trying to mitigate the air and water pollution caused by tendering and docking vessels. The HTV700 is applicable for engines up to 95 kW (127 hp) while the HTM700 is capable of 140kW (187 hp). Both Packages are equipped with a come home feature.

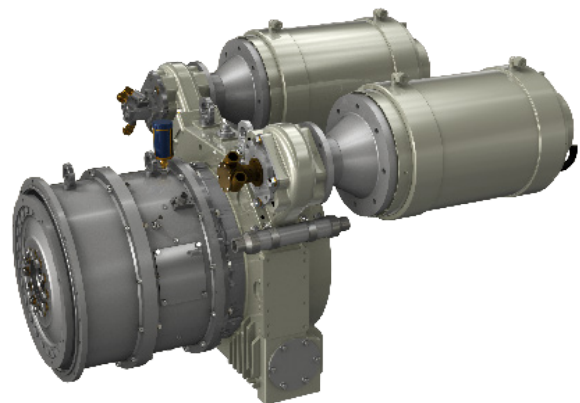
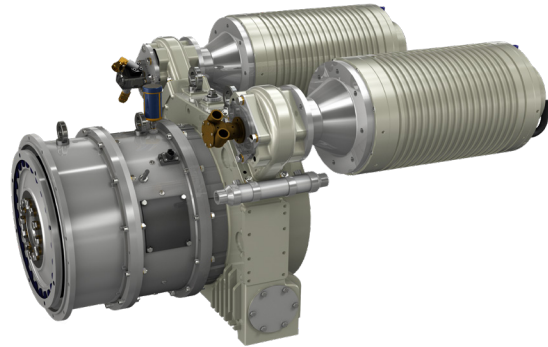
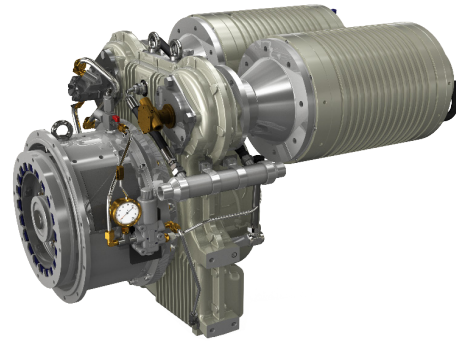
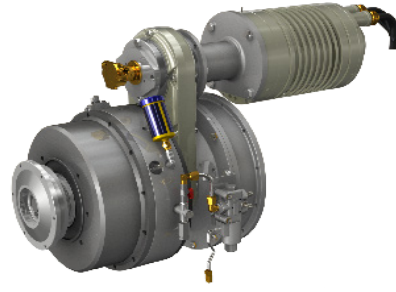

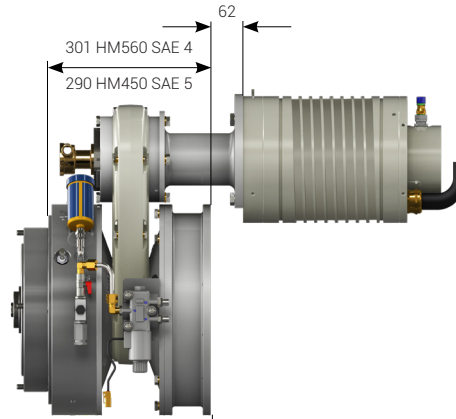
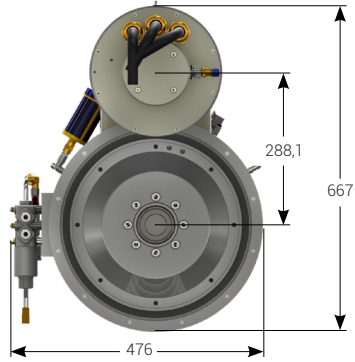

HM450 Hybrid Module
 HM560 Hybrid Module
 Max N° of Electric Machine: 1
 Max Tot Elec. Input Power:
 46hp @ 3000rpm

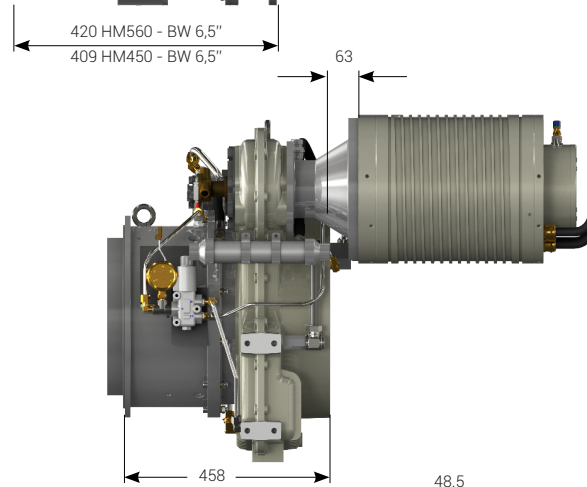
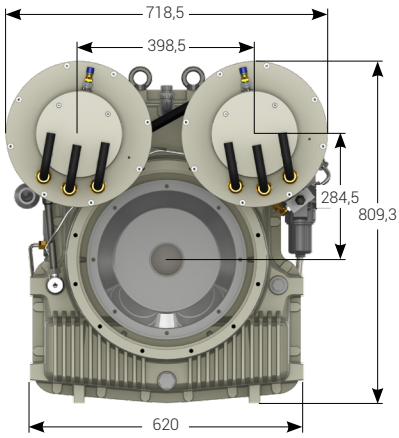

HM2000 Hybrid Module
 Max N° of Electric Machine: 2
 Max Tot Elec. Input Power:
 201hp @ 3000rpm

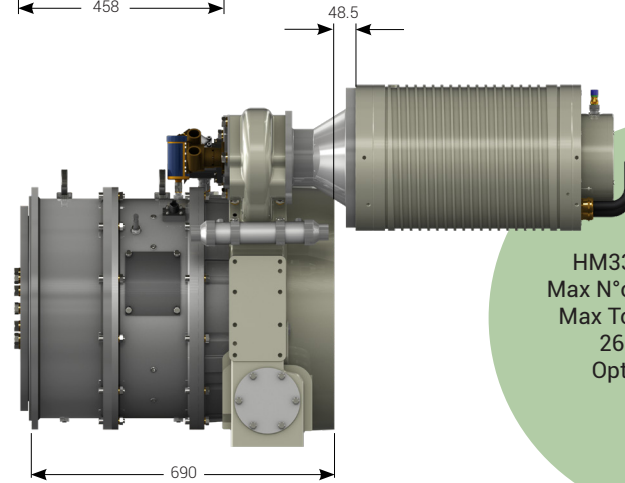
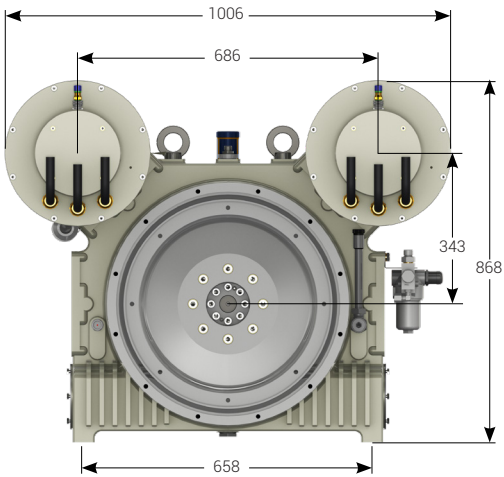

HM3350 Hybrid Module
 Max N° of Electric Machine: 2
 Max Tot Elec. Input Power:
 268hp @ 3000rpm
 Optional PTO heads

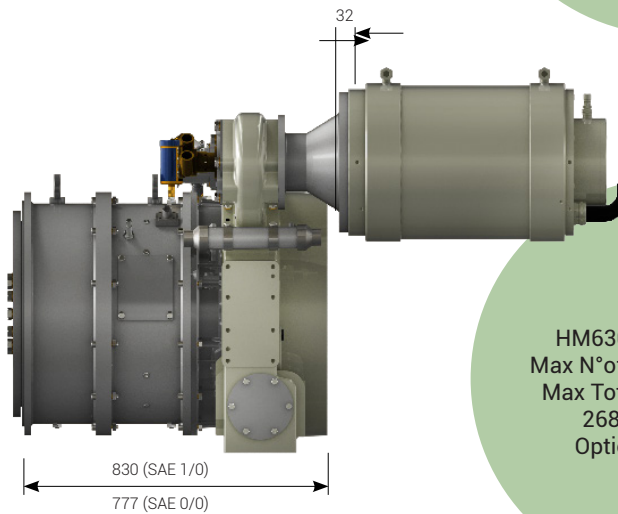
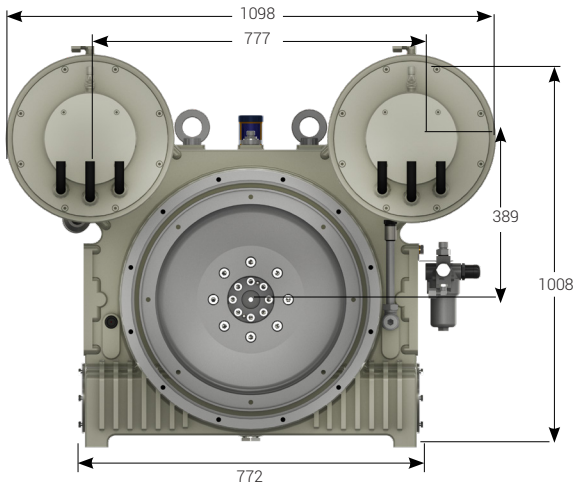

HM6300 Hybrid Module
 Max N° of Electric Machine: 2
 Max Tot Elec. Input Power:
 268hp @ 3000rpm
 Optional PTO heads

Why Transfluid

By dedicating significant resources in the research and development of the Hybrid System range of products, Transfluid is capable of providing complete hybrid solutions as well as the technical support required by manufacturers to implement these products.

Transfluid's Hybrid System easily integrates into traditional propulsion systems assuring an efficient solution to green power and fuel economy.

All modules fit between the engine and transmission, occupying limited space, as though they are an integrated and independent component in the propulsion driveline.

Ecological sustainability, fuel savings, and energy management of Hybrid solutions are just some of the advantages. With the "booster" function, designers can consider a lower power engine yet still maintain the desired performances.

Ship owners can retrofit their vessels thereby providing lower costs and profiting from immediate benefits.

Transfluid is not just a supplier, but also a partner. By providing innovative technology coupled with competitive pricing, even the most difficult hybrid problems can be quickly solved.



HYBRID MARINE TRANSMISSION	INPUT & OUTPUT Standard (1) SAE J617 & J620	MAX INPUT TORQUE Nm (lb-ft)	MARINE kW (hp) - rpm	WEIGHT kg (lbs)
HM450	SAE5-8" (5)	450 (332)	100 (134)-3500	95 (209)
HM560	SAE4-10" (5)	560 (414)	180 (240)-3500	120 (265)
HM2000	SAE3-11.5"	2000 (1478)	435 (580)-3300	350 (772)
HM3350	SAE1-14"	3350 (2476)	620 (830)-2300	560 (1236)
HM6300	SAE1/0-14"/18"	6300 (4647)	1230 (1650)-2300	900 (1986)
HTM700	SAE4-10" (4)	560 (414)	140 (185)-3200	221 (487)
HTM1000	SAE3-11.5"	700 (517)	175 (238)-3200	450 (992)

(1) SAE J620: different Input or Output connections available upon request

(2) Without drop box & brake

(3) With cooler

(4) DIN 120 and SAE 1410 available

(5) BW 6.5" available

(6) for marine application to find the approved internal combustion engine nominal torque, divide the above listed max torque by 1.25 service factor

HYBRID INDUSTRIAL TRANSMISSION	INPUT & OUTPUT Standard (1) SAE J617 & J620	MAX INPUT TORQUE Nm (lb-ft)	INDUSTRIAL kW (hp) - rpm	WEIGHT kg (lbs)
HM450	SAE5-8" (5)	450 (332)	65 (87)-3000	95 (209)
HM560	SAE4-10" (5)	560 (414)	115 (155)-3000	120 (265)
HM2000	SAE3-11.5"	2000 (1478)	350 (470)-2600	350 (772)
HM3350	SAE1-14"	3350 (2476)	500(670)-2200	560 (1236)
HM6300	SAE1/0-14"/18"	6300 (4647)	920(1230)-2100	900 (1986)
HTV700	SAE4-10" (4)	300 (222)	95(125)-3000	245(2) (540)

(1) SAE J620: different Input or Output connections available upon request

(2) Without drop box & brake

(3) With cooler

(4) DIN 120 and SAE 1410 available

(5) For industrial application to find the approved internal combustion engine nominal torque, divide the above listed max torque by 1.5 service factor

E. MACHINE	WEIGHT kg (lbs)	MAX SPEED rpm	BATTERY Vdc	HYBRID TRANSMISSION
EM180-8	25 (55)	3000	96	HM450
EM180-12	35 (76)	3000	96	HM560-HT700
EM220-20	55 (120)	3000	96	HM560-HT700-HM2000
EM220-35	80 (175)	3000	288	HM560-HM2000-HM3350
EM300-50	135 (295)	3000	288	HM2000-HM3350-HM6300
EM300-75	185 (404)	3000	288	HM2000-HM3350-HM6300
EM300-100	195 (425)	3000	384	HM3350-HM6300

E. MACHINE	MOTOR POWER CONTINUOUS kW (hp)	MOTOR PEAK POWER kW (hp)	GENERATOR kW (hp)
EM180-8	8 (11)	10.5	7 (10)
EM180-12	12 (16)	16	10 (14)
EM220-20	20 (27)	25	17 (23)
EM220-35	35 (48)	45	33 (45)
EM300-50	50 (68)	65	49 (67)
EM300-75	75 (100)	100	72 (98)
EM300-100	100 (134)	130	97 (132)

Working Mode

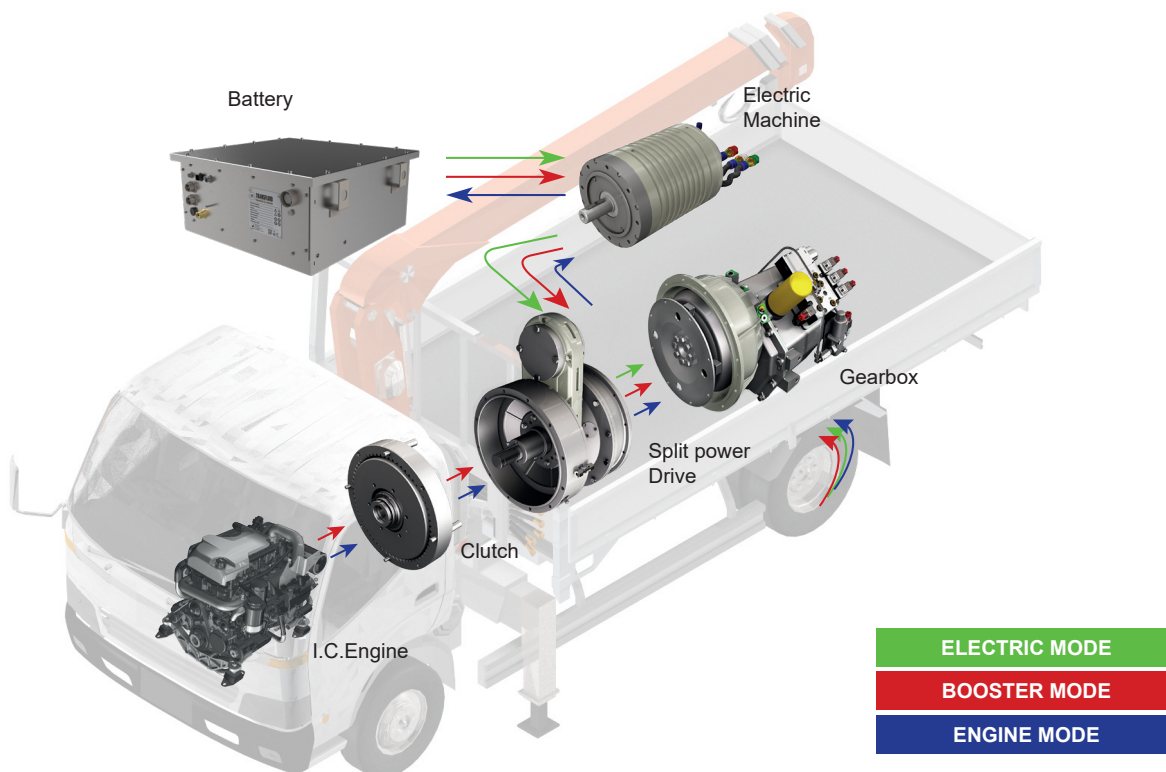
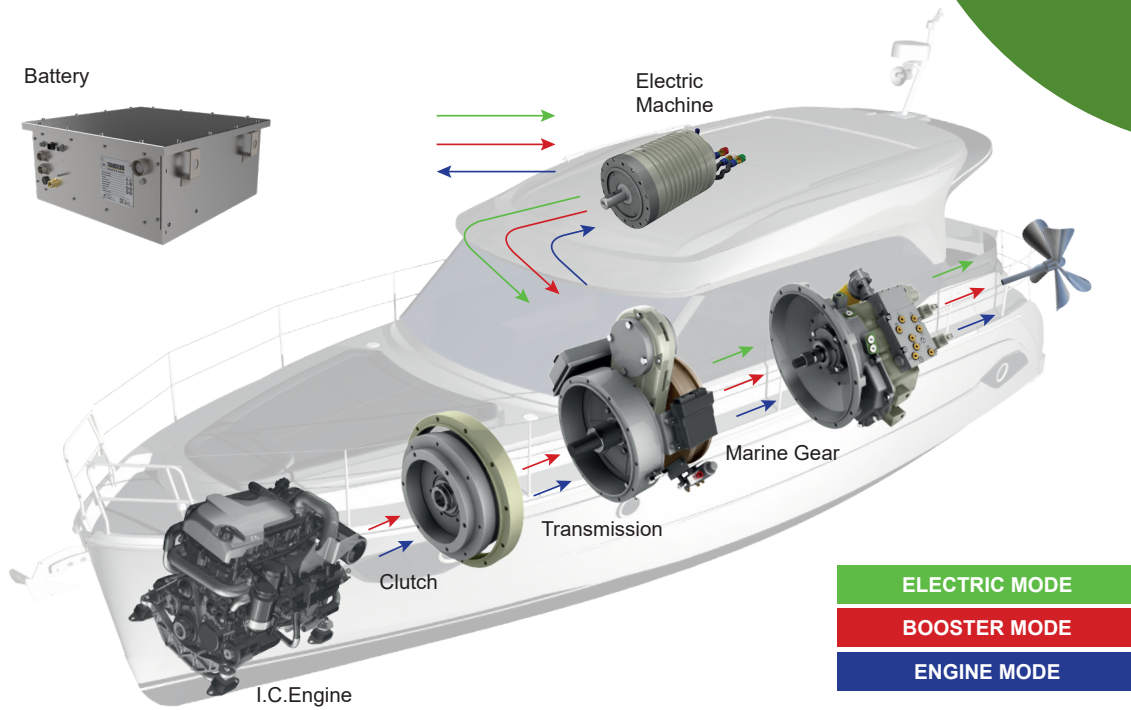

Electric Propulsion System

The EPS (ELECTRIC PROPULSION SYSTEM) provides innovative electric propulsion through the combination of standard Transfluid products. Integrating standard components and adhering to SAE standards produces a new product which easily interfaces with any application.

When used with commercial vehicles, the EPS system includes an automatic "Powershift" RANGERMATIC or REVERMATIC transmission.

For marine propulsion the REVERMATIC marine gear uses the reliable RBD coupling. Both transmissions can be installed with Transfluid's permanent magnets electric motor. This improves the operations of the vehicle or boat by using the efficiency and performance of the electrical machine.

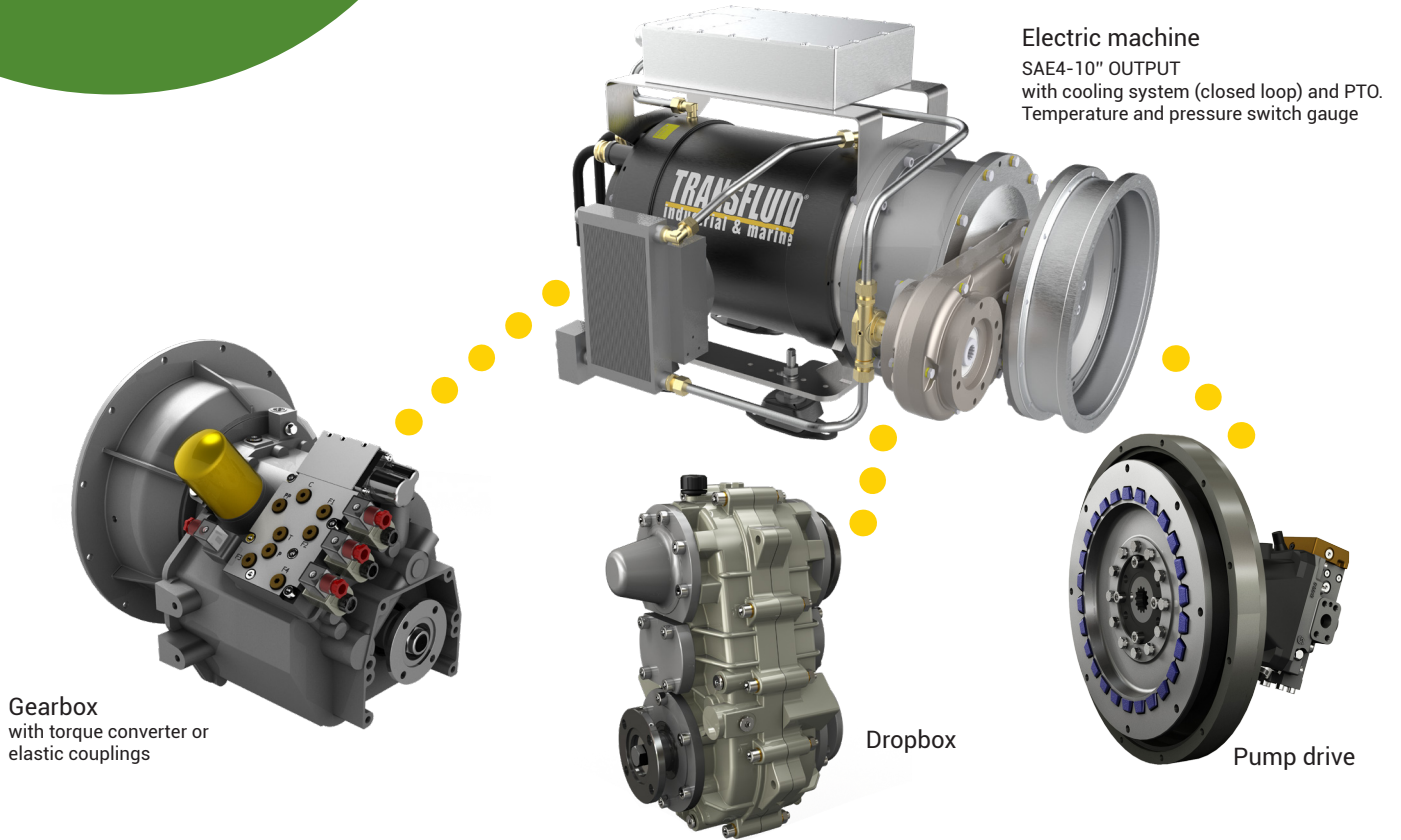

TYPE	POWER at 3000 rpm kW (hp)	PEAK POWER at 3000 rpm kW (hp)	BATTERY VOLTAGE Vdc	WEIGHT kg (lbs)	GEAR BOX	PUMP DRIVE	DROPBOX
EPS05	4 (5)	5 (7)		18 (40)	-		
EPS10	8 (11)	10.5 (13)	96	25 (55)	-		
EPS16	12 (16)	16 (21)	(102)	35 (76)	-		
EPS25	20 (27)	25 (34)		55 (120)	REVERMATIC Single speed	SRBD for hydraulic pump	DP280 2WD or 4WD
EPS45	35 (48)	45 (60)		80 (175)	or		
EPS65	50 (68)	65 (85)	288 (307)	135 (295)	RANGERMATIC two or three speed		
EPS100	75 (100)	100 (127)		185 (404)	(for ratios see catalogue)		
EPS130	100 (136)	130 (169)	384 (409)	195 (425)			

Technical features, dimensions and any other data are not binding. Transfluid S.p.A. reserves the right to change the without notice

EPS Industrial System



[Example of full power-train supply]

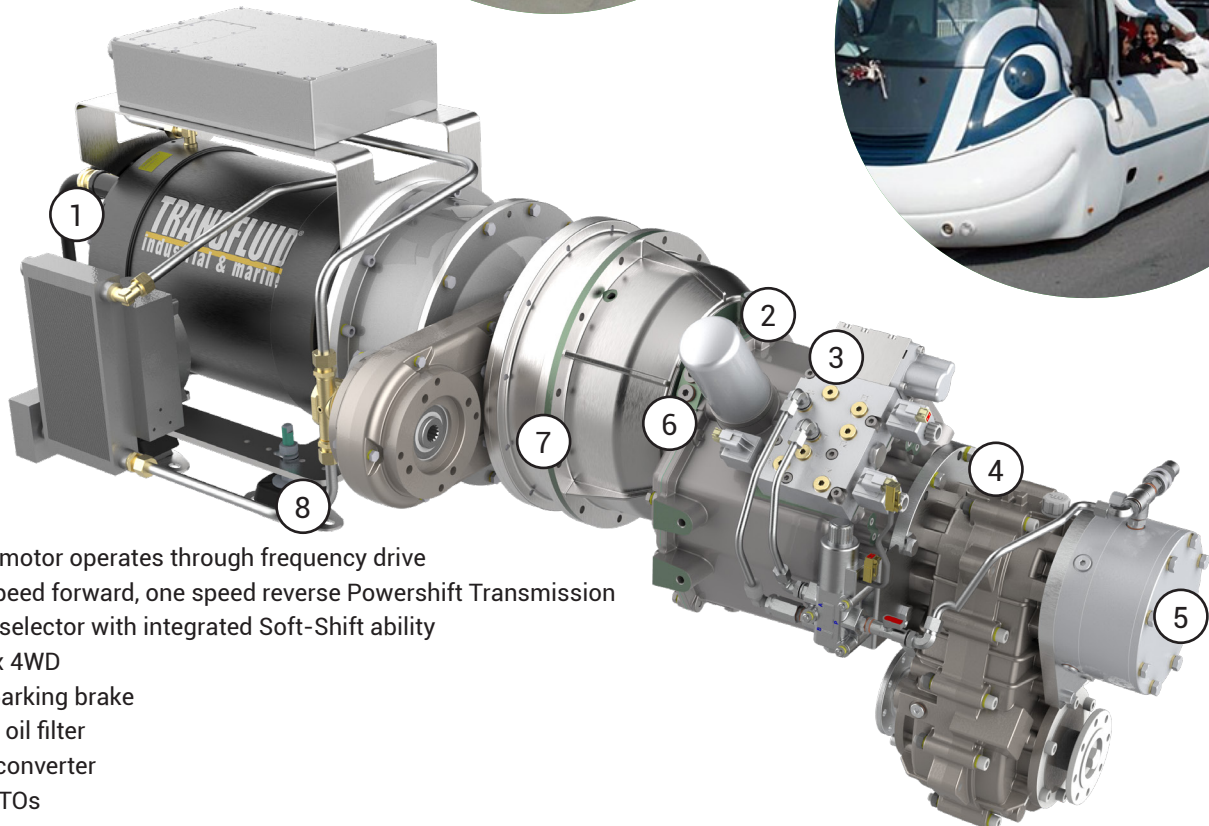

1. Electric motor operates through frequency drive
2. Three speed forward, one speed reverse Powershift Transmission
3. Electric selector with integrated Soft-Shift ability
4. Dropbox 4WD
5. Safety parking brake
6. Spin-on oil filter
7. Torque converter
8. 2 Live PTOs

The innovative concept of EPS consists of an automatic RANGERMATIC "Powershift" transmission coupled to a permanent magnet electric motor. This optimizes the driving experience of the vehicle and enhances the performance of the motor. The RANGERMATIC reduction ratios allow the user to select the optimal ratio according to the operating conditions. The addition of the DROP BOX DP280 on the output of the EPS system provides additional gear ratios to enhance the electric motor performances. Additionally, the drop box is available with two outputs for four-wheel drive applications. This provides identical use and driving of the EPS system to those of a combustion engine. The use of batteries, indispensable for the supply of the electric machines, allows the recovery of kinetic energy during deceleration and braking (Kinetic Energy Recovery System) storing energy that would otherwise be lost, increasing the autonomy of the vehicle.

EPS Marine System

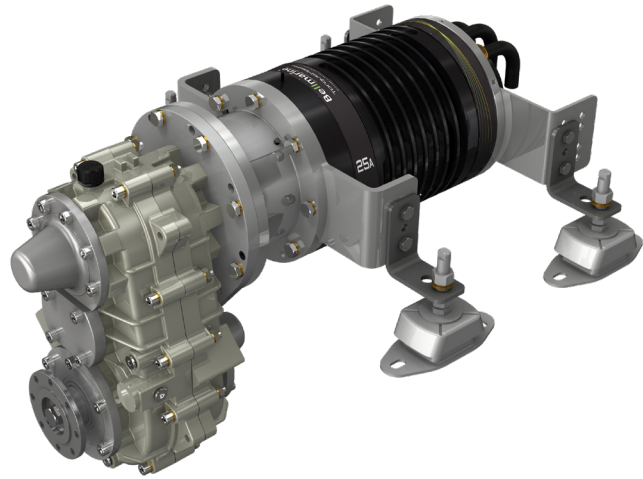

TorqueMaster



SailMaster



SternMaster



DriveMaster



(See also Transfluid-Bellmarine catalogue)



OutboardMaster



ModularMaster







ShaftMaster

Remote monitoring - Fast service

Safe - Reliable - Timely



Annual subscription for remote monitoring and service of Hybrid or Electric System through web portal with password access

-  Gift box with emergency spares kit
-  Delivery of spare parts to the nearest service center within 72 hours
-  Advance notice for maintenance
-  Online monitoring

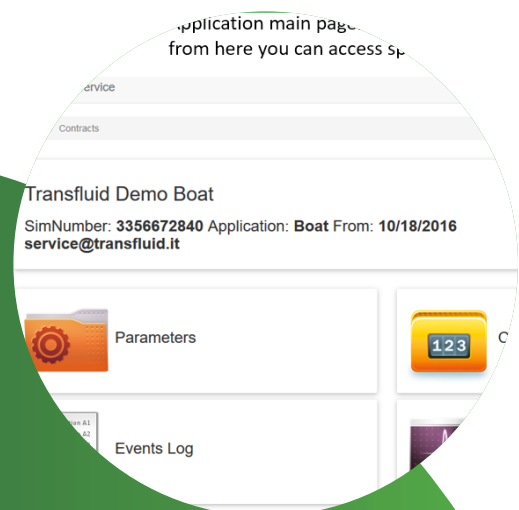

TRANSFLUID®

industrial & marine

ITALY - HEADQUARTERS

TRANSFLUID S.p.A.
Via Guido Rossa, 4
21013 Gallarate (VA)
Ph. +39.0331.28421
info@transfluid.eu

U.S.A.

TRANSFLUID LLC
Auburn, GA 30011
Ph. +1.770.822.1777
salesna@transfluid.us

THE NETHERLANDS

BELLMARINE
NL- 3992 AK, Houten
Ph. +31 (0)85 4868530
info@bellmarine.nl

www.transfluid.us



drive with us

August 2024